



*Barron Equipment  
4710 N Brady St  
Davenport, IA 52806  
1-800-397-6690*

---

# Series 2000 Rigid Dock Shelter

*All Models*

## **Installation Instructions**



Do not install this product unless you read and understand the Warnings and Installation Instructions contained in this manual. Failure to do so could result in serious injury or death.

# SERIES 2000 DOCK SHELTER

## Installation Instructions

### CHECK FIRST:

To ensure proper measurement to accommodate the Dock Shelter you are installing, check the following:

A. Check the door height and width to verify that your shelter frame is properly sized.

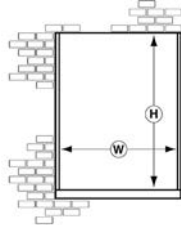

B. It is recommended that the shelter frame project 14"-18" beyond the dock bumper. (Example: At a flush dock with a bumper projection of 6", standard shelter projection should be 20"-24" for standard 11' 6" wide shelter.)

C. If the approach is not level, check to make sure shelter frame tapers to accommodate the angle of the truck.

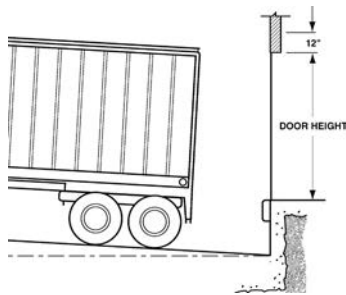

D. Check the heights of incoming carriers that will be utilized at this door, to ensure that the shelter frame is of proper elevation to accommodate the height range of these vehicles. The top of a Rigid Frame Shelter should be kept as close to 15' 0" off grade as possible.

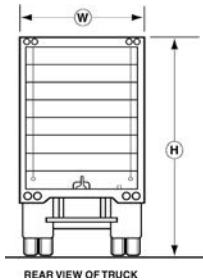

E. In 95% of installations, the inside edge of the face of the side curtain should be 7' 0" I.D.

### ⚠ WARNING

Improper lifting or attachment of seal/shelter can cause serious injury or death.

Installation requires:

- A structurally sound building wall,
- Barricades to keep people away from the area,
- Proper attachment of anchoring devices,
- Two or more people,
- A lifting device capable of lifting at least 500 lbs. at the installation angle.

If you have questions, contact your supervisor, your local Fairborn distributor or Fairborn USA at 1-800-262-1188.

### INSTALLATION:

NOTE: Left and right are distinguished by facing the exterior of the building.

1. Take given width of unit (or length of head member); find center line of door opening, and measure over each way 1/2 of the unit width. This will give you the outside edge of steel guards. Plumb, mark, and fasten guards to foundation wall with the top channel at the same elevation as dock height. There are right and left steel guards distinguishable by holes in the top channel. The hole is 1 3/4" over from outside edge of guard. This hole is used to secure side frames to guards with supplied bolts (side frame requires drilling).

2. Remove contents from shipping cartons. NOTE: Using cartons as protective tarp prevents the units from becoming soiled. Aluminum angles are shipped intact to side and top frame members. Remove these angles before proceeding with fastening of curtains. Curtains may be installed before or after frame members are anchored to building. Before securing side members to building remove wood shipping blocks at top of side members.

3. Fasten 3/8" Dia. x 4" hanger bolt assembly into center hole of front head member, using deep-well socket so that washer and hex nut are submerged in counter bored hole (predrill center cross member 1/4" Dia. x 1 1/2" deep). Resulting stud extension (3/8-16 x 1" approx.) is to be used in securing center grommet of head curtain and center of aluminum angle together with washer and locknut.

Secure side curtains and remainder of head curtain to the frame members by means of 5/16" x 2 1/2" hex head cap screws, using a flat washer at the head of the cap screw, through the aluminum angle, the grommets in curtain, the hole in the stays, predrilled holes in wood member, washer, then locknut. Tighten securely.

4. Plumb and secure side frames, with fiberglass on the outside, on top and flush with the outside edge of the steel guards. Secure side member at a minimum of (3) locations best suited for holding, using adequate anchor. Also secure side member to steel guards as in Step 1. Plumb and secure right side member using same procedure.

5. Check the O.D. width of side members at top to verify correct unit width!

6. Secure head member to building at top of side frames by use of the pre-installed 5/16" x 2 1/2" hex head lag screws. Anchor to building a minimum of (4) locations. Secure the side member protruding fiberglass to each end of the head member by means of furnished wood screws.

7. Tension cords have been factory attached to the inside top corners of the side curtains. Attach the free ends of these tension cords to the screw eyes (also factory attached) directly above on the front inside face of the head frame. Close S-Hooks.

8. Secure wind straps to head curtain with 3/8" x 1" stove bolt washers and locknut, nut end pointing away from the shelter. Wind strap should be secured to the side member by drilling a 3/8" hole through the aluminum angle and side frame, and using 3/8" x 2 1/2" bolt, washers, and nuts supplied.

9. Fasten foam bottom pads to each side of side frames by using (4) "Z" brackets and (12) #14 wood screws per bottom pad. Lag the "Z" bracket to the wood backing with bottom pad in such a fashion as to recess the thickness of the wood within the frame. The leg of the "Z" bracket with (2) holes is secured to the bottom pad. The other leg with (1) hole secures to the horizontal members of the side frames. Space "Z" brackets 3" in from the wood back to the outside edge of bracket.

10. All fasteners must be tight, special emphasis on those securing the curtains to the frames and protective guards to the foundation.

11. BE SURE TO CAULK AND FILL ALL VOIDS!!

### SUGGESTED MOUNTING METHODS:

(Mounting anchors not included.)

Concrete or Brick Wall: Try to hit mortar joints. Use 1/2" or 3/8" x 3" expansion anchors. use through-bolt fastening if anchors will not hold, 3/8" threaded rod is recommended.

Precast Concrete: Same as above.

Metal Skin Building: Through-bolt fastening as above. Use a back-up plate (steel or wood) to support bolts or anchor through existing building horizontal and vertical structural members when possible.

**NOTE:** Dock Seals must have adequate bumper protection, 4" minimum.

#### STEEL GUARD DATA

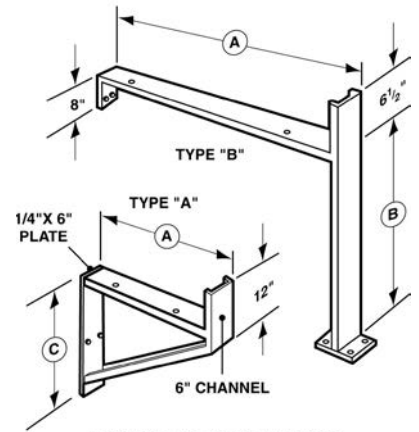

"A" TOTAL STEEL GUARD PROJ.  
(STD. 4" GREATER THAN SIDE FRAME BOTTOM PROJECTION)

"B" DIM: MEASURE FROM DRIVE GRADE TO DOCK LEVEL @ "A" DIM. FROM BUILDING

"C" STEEL GUARD PROJ.	"C" DIM.
22"-28"	20"
34"-40"	27"
46"-52"	34"

NOTE: GREATER PROJECTION THAN 52" USE TYPE "B"

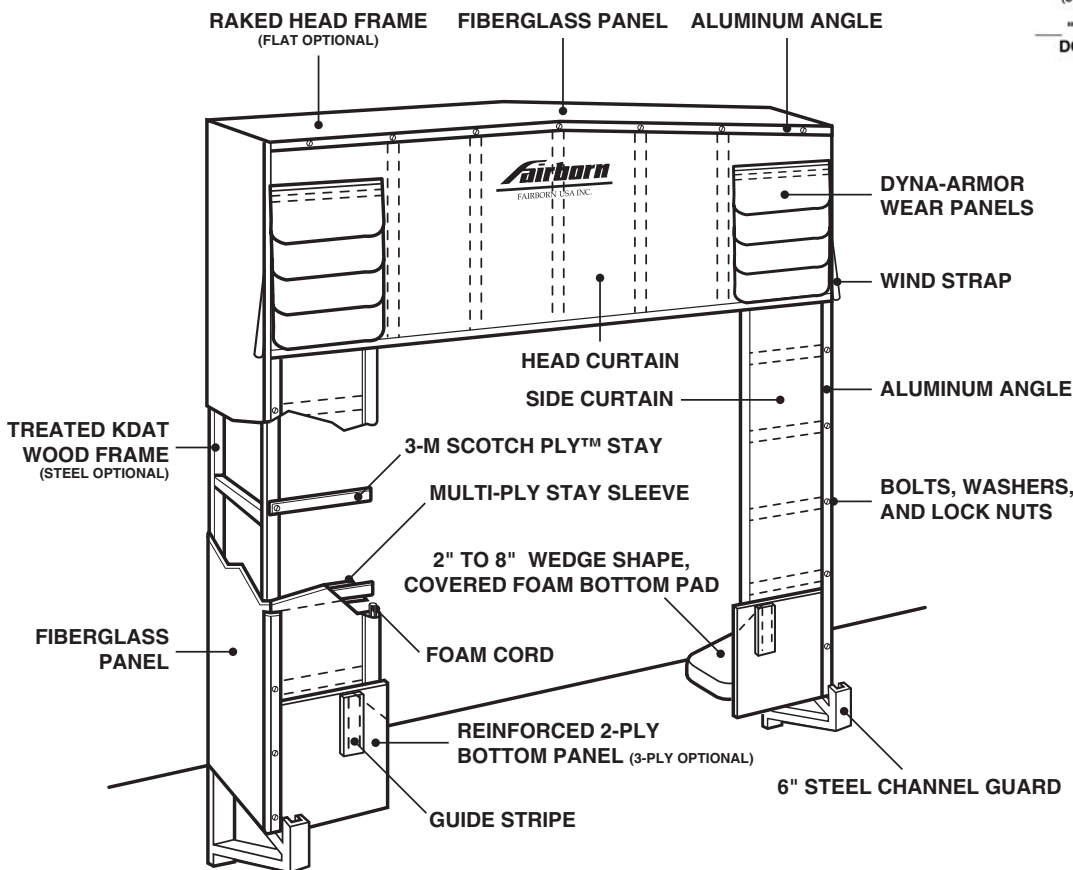

---

## OPTIONAL COMMON SIDE MEMBER:

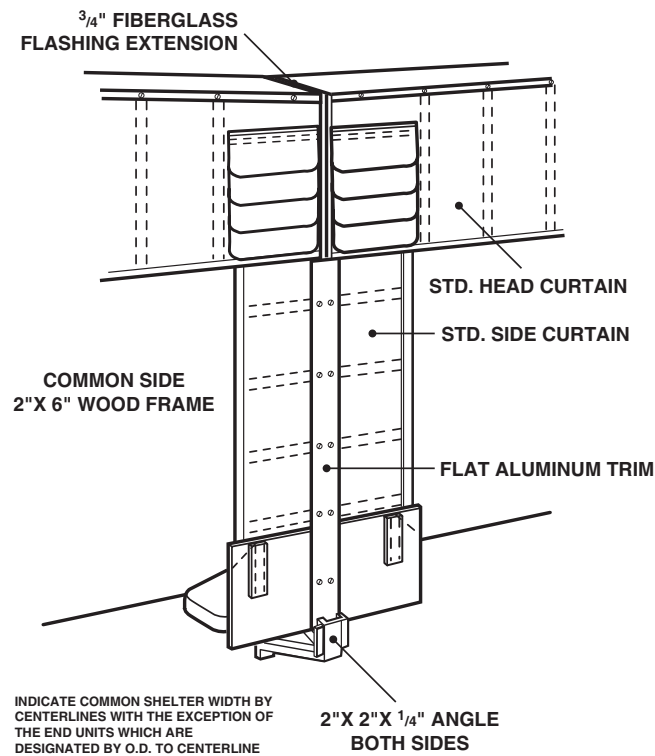

---

## LIMITED PRODUCT WARRANTY

### GENERAL

FAIRBORN USA INC. EXTENDS THIS LIMITED WARRANTY TO THE ORIGINAL BUYER AND WARRANTS THAT ALL PRODUCTS MANUFACTURED BY FAIRBORN SHALL BE FREE FROM ORIGINAL DEFECTS IN WORKMANSHIP AND MATERIALS FOR ONE YEAR FROM DATE OF SHIPMENT, PROVIDED SAME HAVE BEEN PROPERLY SIZED FOR THE APPLICATION, STORED, INSTALLED, SERVICED, MAINTAINED AND OPERATED. THIS WARRANTY SHALL NOT APPLY TO PRODUCTS WHICH HAVE BEEN ALTERED OR REPAIRED IN ANY WAY SO AS, IN FAIRBORN'S JUDGMENT, AFFECTS ITS PERFORMANCE OR RELIABILITY, NOR WHICH HAVE BEEN IMPROPERLY INSTALLED OR SUBJECTED TO MISUSE, NEGLIGENCE, OR ACCIDENT, OR INCORRECTLY USED IN COMBINATION WITH OTHER SUBSTANCES. COMPENSATION FOR PRODUCTS HAVING WEAR AND TEAR CAUSED BY NORMAL USAGE IS NOT PROVIDED FOR BY THIS WARRANTY.

### DYNALON

IN CONSIDERATION OF THE SAME CONDITIONS AND RESTRICTIONS AS STATED ABOVE, DYNALON IS WARRANTED AGAINST THE EFFECTS OF WEATHERING FOR A PERIOD OF FIVE YEARS AS DESCRIBED WITHIN. AS PART OF THIS AGREEMENT THE TERM "WEATHERING" IS DEFINED AND LIMITED TO THE EFFECTS OF SUNLIGHT (ULTRAVIOLET RADIATION), WATER (ATMOSPHERIC PRECIPITATION), COLD, AND HEAT. THIS WARRANTY IS NOT APPLICABLE IF THE DYNALON HAS BEEN EXPOSED OR SUBJECTED TO CORROSIVE AGENTS, CHEMICALS, OR MECHANICAL ABUSE.

IN THE EVENT THAT THE EFFECTS OF WEATHERING RENDER THE PRODUCT, CONSTRUCTED OF DYNALON, INOPERABLE DUE TO CRACKING, CHECKING, OR ULTRAVIOLET BREAKDOWN, THEN FAIRBORN USA INC., AFTER INSPECTION AND VERIFICATION, WILL FURNISH REPLACEMENT MATERIALS, AT NO COST TO CUSTOMER, TO FIX OR REPAIR AND/OR REPLACE THE INOPERABLE COMPONENTS. FAIRBORN SHALL NOT BE RESPONSIBLE FOR THE ON-SITE LABOR, FREIGHT, LOSS OF USE OR ANY OTHER EXPENSE RELATED TO THE AFOREMENTIONED CLAIM.