

SERIES 1400
HEAD CAP TYPE
DOCK SEAL

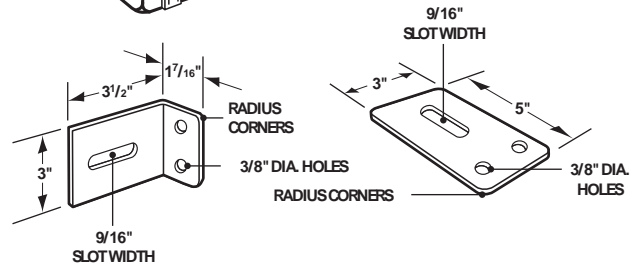

ANGLE AND FLAT MOUNTING BRACKETS

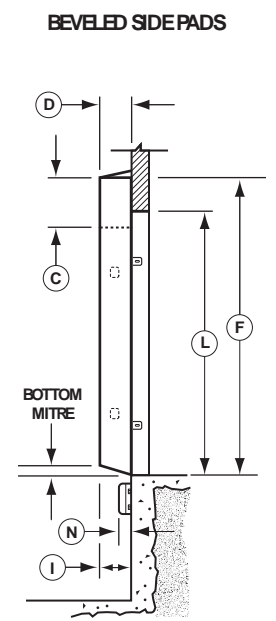
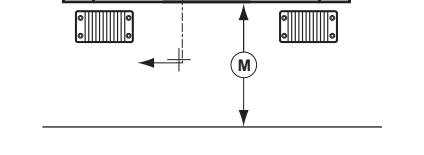
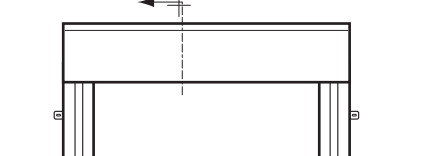
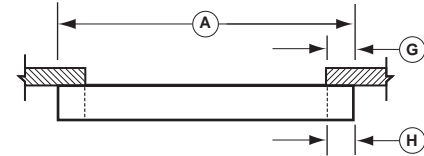
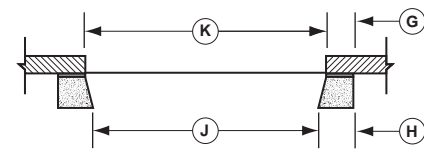
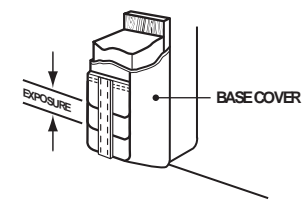
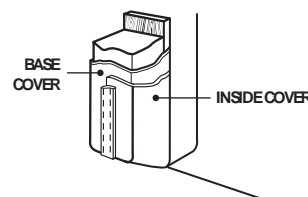
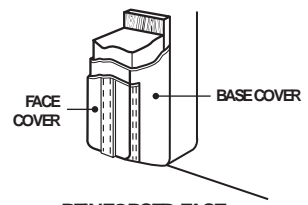
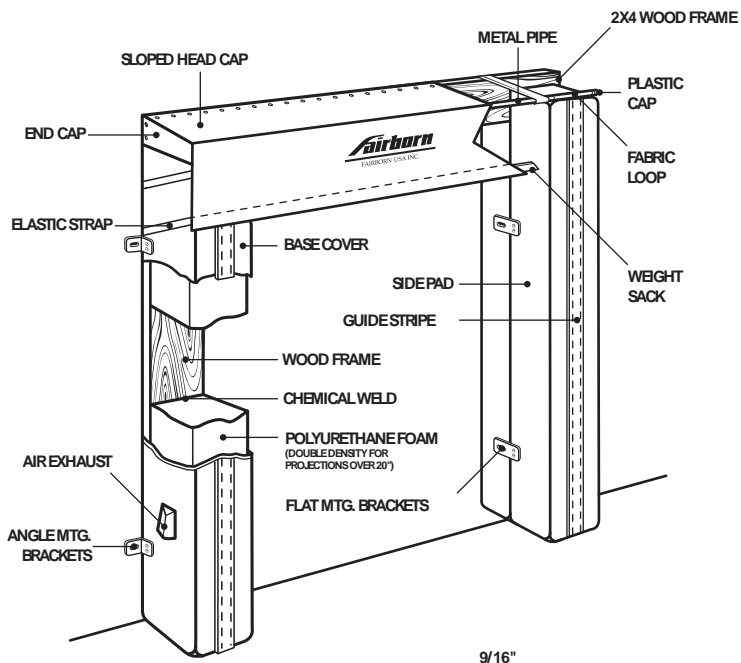
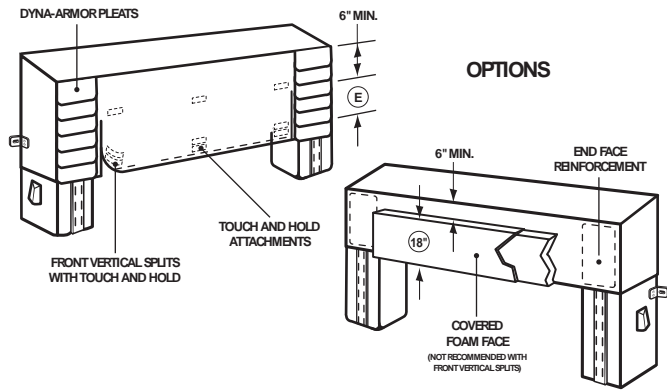

HEAD CAP DATA

- ____ "A" WIDTH
- ____ "C" HEIGHT AT FACE
- ____ "D" TOTAL PROJECTION
- ____ BASE FABRIC
- ____ COLOR

END FACE REINFORCEMENT

- ____ FABRIC
- ____ COLOR

DYNA-ARMOR ENDS

- ____ FABRIC
- ____ COLOR
- ____ "PLEAT" EXPOSURE

FRONT VERTICAL SPLITS

- ____ "E" SPLIT HEIGHT (C-6"= MAX. SPLIT)

TOUCH AND HOLD ATTACHMENT

ROPE/PULLEY SYSTEM

- COVERED FOAM FACE 4" THICK X 18" HIGH X "J" SIDE PAD FACE I.D.

SIDE PAD DATA

- ____ "F" LENGTH AT REAR
- ____ "G" WIDTH AT REAR
- ____ "H" WIDTH AT FACE
- ____ "D" TOTAL PROJ. AT TOP
- ____ "I" TOTAL PROJ. AT BOTTOM
- ____ "J" SIDE PAD FACE I.D.

BLOCKOUT (IF REQUIRED)

- PROJ. TOP BOTTOM
- ____ FABRIC
- ____ COLOR

FACE REINFORCEMENT

- ____ FABRIC
- ____ COLOR

INSIDE EDGE REINFORCEMENT

- ____ FABRIC
- ____ COLOR

DYNA-ARMOR PLEATS

- ____ FABRIC
- ____ COLOR
- ____ "PLEAT" EXPOSURE

FORMED STEEL BACK

- PAINTED GALVANIZED

NON-ROT BACK

GENERAL INFORMATION

- ____ "K" DOOR WIDTH
- ____ "L" DOOR HEIGHT
- ____ "M" DOCK HEIGHT
- ____ "N" DOCK BUMPER/LEDGE COMBINED PROJECTION

DRIVE APPROACH:

- LEVEL DECLINED INCLINED

FB: ____ QTY. ____ SHEET ____ OF ____



4710 N Brady St, Davenport, IA 52806
 800-397-6690
 VISIT US AT... WWW.BARRONEQ.COM

JOB: _____

LOCATION: _____

CONTRACTOR: _____ **ARCHITECT:** _____

APPROVED BY SIGNATURE: _____