



*Barron Equipment
4710 N Brady St
Davenport, IA 52806
1-800-397-6690*

Series 2200 Soft-Sided Dock Shelter

All Models

Installation Instructions



Do not install this product unless you read and understand the Warnings and Installation Instructions contained in this manual. Failure to do so could result in serious injury or death.

SERIES 2200 SOFT-SIDED DOCK SHELTER

Installation Instructions

CHECK FIRST:

To ensure proper measurement to accommodate the Dock Shelter you are installing, check the following:

A. Check the door height and width to verify that your shelter frame is properly sized.

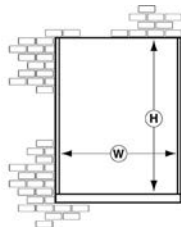

B. It is recommended that the shelter frame project 14"-18" beyond the dock bumper. (Example: At a flush dock with a bumper projection of 6", standard shelter projection should be 20"-24" for standard 12' 0" wide shelter.)

C. If the approach is not level, check to make sure shelter frame tapers to accommodate the angle of the truck.

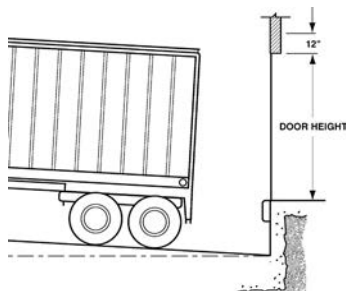

D. Check the heights of incoming carriers that will be utilized at this door, to ensure that the shelter frame is of proper elevation to accommodate the height range of these vehicles. The top of a Soft Sided Shelter should be kept as close to 15' 0" off grade as possible.

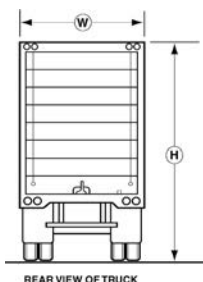

E. In 95% of installations, the inside edge of the face of the side curtain should be 7' 0" I.D.

⚠ WARNING

Improper lifting or attachment of seal/shelter can cause serious injury or death.

Installation requires:

- A structurally sound building wall,
- Barricades to keep people away from the area,
- Proper attachment of anchoring devices,
- Two or more people,
- A lifting device capable of lifting at least 500 lbs. at the installation angle.

If you have questions, contact your supervisor, your local Fairborn distributor or Fairborn USA at 1-800-262-1188.

INSTALLATION:

1. Identify yourself to the appropriate on-site customer personnel. Follow customer's instructions as to: 1) the location where tools, equipment and material can be stored on site; and 2) the installation sequence for each opening. Review all job site safety programs and procedures to ensure your compliance. Obtain all appropriate permits required to perform this work.

2. Review all drawings and specifications related to this portion of the project with particular attention to special instructions and/or conditions. Verify the facility conditions to the appropriate dock related dimensions illustrated on Drawings or documents (Door width and height, dock height, distance between openings, bumper projections, drive grade, and etc.).

3. Clear installation area of all unnecessary obstructions. Cordon off vehicular and pedestrian traffic.

4. Unpack dock shelter components, checking completeness to all bills of lading, bills of materials and installation instructions. Additionally check basic unit dimensions to assure that the correct units have arrived at the job site (lengths, widths, projections and etc.).

5. Mount left and right head frame support brackets to top, rear of appropriate side pads (or rear of block out, if applicable) using #14 x 1" lg. flat head wood screws or lag screws as provided (bracket gusset to exterior of side pad). Center the side pad assemblies on the opening width, maintaining unit O.D. Be sure to keep the side pads square and plumb. Secure each side pad to the building face utilizing six (6) angle mounting brackets, 5/16" x 2" lg. lag screws, 5/16" flatwashers and appropriate anchors.

6. Position head frame level, over side pads, against building face, into gusseted steel support brackets at both ends and secure frame to brackets with (4) or (6) 5/16" x 2" lg. lag screws and 5/16" flatwashers. Secure head frame to wall with appropriate anchors through rear wood member.

7. Check condition of above assembled components to assure they are plumb, square and level. Shim or adjust as required.

8. Attach side curtain assemblies to faces of side pads utilizing the 3/8" black, steel flatwashers and 3/8-16 hex locknuts provided to secure. (Face reinforcements and guide stripes to be at bottom.) Do not over torque nuts.

9. Tension cords have been factory attached to the inside, top corners of the side curtains. Attach the free ends of these tension cords to the screw eyes (also factory attached) directly above on the front, inside face of the head frame, Close S-hooks.

10. Position fabric flap at top, front of each side pad against the face of the head frame. Pull up so that flap is tensioned and secure with #14 x 1" lg. flat head wood screws through grommetted holes provided.

11. Fasten 3/8" Dia. x 4" hanger bolt assembly into center hole of front head member, using deep-well socket so that washer and hex nut are submerged in counter bored hole (pre-drill center cross member 1/4" Dia. x 1 1/2" deep). Resulting stud extension (3/8-16 x 1" approx.) is to be used in securing center grommet of head curtain and center of aluminum angle together with washer and locknut.

Secure three (3) piece head curtain to the head frame by means of 5/16" x 2 1/2" hex head cap screws, using a flat washer at the head of the cap screw, through the aluminum angle, the grommets in curtain, the hole in the stays, pre-drilled holes in wood member, washer, then locknut. Mount smaller end curtains first. (Distinguish right hand and left hand end curtains by taper at top. This should coincide with raked head frame.) Mount center curtain section next, in front of end curtains. The outermost mounting hold at each end of the center curtain will share a mounting screw with the innermost hole in each end curtain.

12. Install bottom pad to interior face of side pads by lacing with ropes provided through grommetted holes in matching fabric flaps. ("No Step" label to be legible from dock.) In the event that a fabric covered wood blockout has been furnished with the side pad, nail attach the rear portion of the bottom pad flaps to the blockout through the grommetted holes provided.

13. Apply silicone based caulking over top exterior of the head frame. Bead size to be adequate for adhesion to the continuous rear portion of the head frame and adjacent wall surface.

14. Clean unit and clear area of all cartons, scrap and debris generated as a result of the dock seal installation.

NOTE 1) When installing the anchors described within, be sure to set anchors in accordance with the anchor manufacturer's recommended installation procedures to ensure maximum holding strength.

SUGGESTED MOUNTING METHODS: (Mounting anchors not included.)

Concrete or Brick Wall: Try to hit mortar joints. Use 1/2" or 3/8" x 3" expansion anchors. use through-bolt fastening if anchors will not hold, 3/8" threaded rod is recommended.

Precast Concrete: Same as above.

Metal Skin Building: Through-bolt fastening as above. Use a back-up plate (steel or wood) to support bolts or anchor through existing building horizontal and vertical structural members when possible.

NOTE: Dock Seals must have adequate bumper protection, 4" minimum.

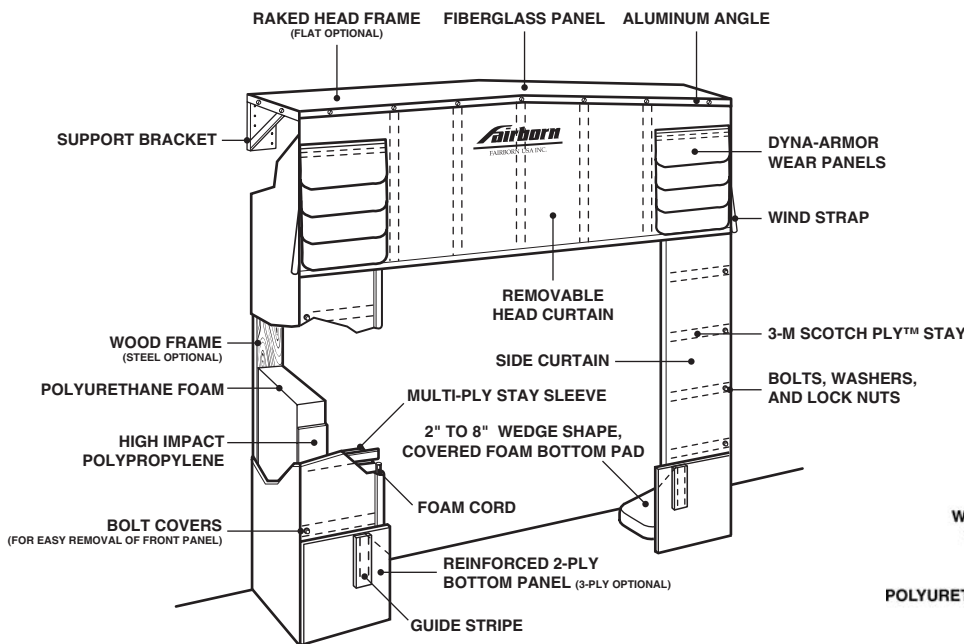

HEAD CURTAIN AND SIDE CURTAINS ARE EASILY REMOVED BY SIMPLY TAKING OFF THE BOLT AND BOLT COVERS. THIS MAKES REPLACING WORN CURTAINS EASY AND EFFICIENT.

HEADER SUPPORT BRACKET DETAIL (SUPPORTS FIBERGLASS HEAD PANEL)

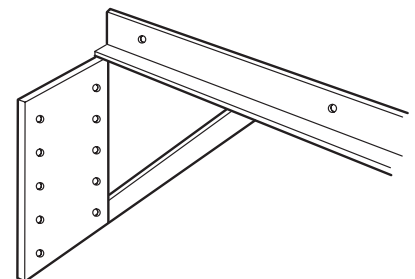

CUT-AWAY CONSTRUCTION DETAIL

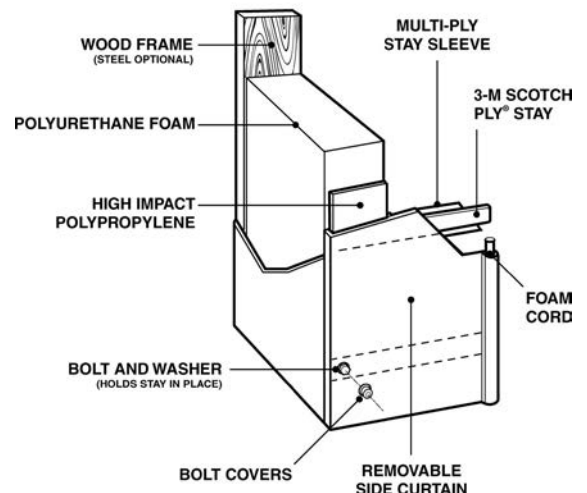

LIMITED PRODUCT WARRANTY

GENERAL

FAIRBORN USA INC. EXTENDS THIS LIMITED WARRANTY TO THE ORIGINAL BUYER AND WARRANTS THAT ALL PRODUCTS MANUFACTURED BY FAIRBORN SHALL BE FREE FROM ORIGINAL DEFECTS IN WORKMANSHIP AND MATERIALS FOR ONE YEAR FROM DATE OF SHIPMENT, PROVIDED SAME HAVE BEEN PROPERLY SIZED FOR THE APPLICATION, STORED, INSTALLED, SERVICED, MAINTAINED AND OPERATED. THIS WARRANTY SHALL NOT APPLY TO PRODUCTS WHICH HAVE BEEN ALTERED OR REPAIRED IN ANY WAY SO AS, IN FAIRBORN'S JUDGMENT, AFFECTS ITS PERFORMANCE OR RELIABILITY, NOR WHICH HAVE BEEN IMPROPERLY INSTALLED OR SUBJECTED TO MISUSE, NEGLIGENCE, OR ACCIDENT, OR INCORRECTLY USED IN COMBINATION WITH OTHER SUBSTANCES. COMPENSATION FOR PRODUCTS HAVING WEAR AND TEAR CAUSED BY NORMAL USAGE IS NOT PROVIDED FOR BY THIS WARRANTY.

DYNALON

IN CONSIDERATION OF THE SAME CONDITIONS AND RESTRICTIONS AS STATED ABOVE, DYNALON IS WARRANTED AGAINST THE EFFECTS OF WEATHERING FOR A PERIOD OF FIVE YEARS AS DESCRIBED WITHIN. AS PART OF THIS AGREEMENT THE TERM "WEATHERING" IS DEFINED AND LIMITED TO THE EFFECTS OF SUNLIGHT (ULTRAVIOLET RADIATION), WATER (ATMOSPHERIC PRECIPITATION), COLD, AND HEAT. THIS WARRANTY IS NOT APPLICABLE IF THE DYNALON HAS BEEN EXPOSED OR SUBJECTED TO CORROSIVE AGENTS, CHEMICALS, OR MECHANICAL ABUSE.

IN THE EVENT THAT THE EFFECTS OF WEATHERING RENDER THE PRODUCT, CONSTRUCTED OF DYNALON, INOPERABLE DUE TO CRACKING, CHECKING, OR ULTRAVIOLET BREAKDOWN, THEN FAIRBORN USA INC., AFTER INSPECTION AND VERIFICATION, WILL FURNISH REPLACEMENT MATERIALS, AT NO COST TO CUSTOMER, TO FIX OR REPAIR AND/OR REPLACE THE INOPERABLE COMPONENTS. FAIRBORN SHALL NOT BE RESPONSIBLE FOR THE ON-SITE LABOR, FREIGHT, LOSS OF USE OR ANY OTHER EXPENSE RELATED TO THE AFOREMENTIONED CLAIM.