

Fully powered straddle Logiflex Maxi - makes work easy

High flexibility and efficiency - a fully powered straddle Logiflex Maxi can transport, lift and handle different goods. All types of pallets - also closed pallets - can be handled.

Large range of optional extras ensures an optimum flexibility.

The design puts focus on the safety and ergonomic working conditions of the user - Logiflex Maxi can be adjusted to the individual user, and the ergonomic correct handle ensures the user a relaxed hold.

High quality is ensured through an extended test program and in cooperation with experts in Health and Safety.



Technical Specifications

Straddle legs make it possible to handle many different pallet types.

High performance with AC technology

- Easy setting of e.g. driving speed, acceleration and deceleration
- Long operating time per charge

Strong construction ensures a long operating life and low maintenance costs.



Available with Rotator and/or optional extras, e.g. drum turner, remote control and level control.



Possible to operate with the handle upright. Central location of all control buttons.



Adjustable forks are available in many different lengths and types.

Product (measured in inch)	SELS MAXI	SELS MAXI	SELS MAXI	SELS MAXI	SELS MAXI	SELS MAXI	SELS MAXI	SELS MAXI	SELS MAXI	
Capacity in lbs.	2200/3000*	2200/3000*	2200/3000*	2200/3000*	2200	2200	2200	2200	2200	
Lifting height forks: wrap-over/chisel	h_3	35/34	46/45	54/53	62/61	74/73	79/78	95/94	111/110	
Fork length	l	23.5**, 31.5**, 42, 45, 60***								
Overall height	h_1	52	60	68	76	88	60	68	76	
Overall width	b_1	6.5 + b_4								
Fork span min./max.	b_5	Wrap-over: 13.25/31.5, bar: 9/27, chisel: 9/27								
Length without forks	l_2	27,7								
Overall length with 45" forks	l_1	73				73.5				
Overall height	h_4	Without telescopic mast						98	114	130
Lowered height, forks	h_{13}	Chisel: 1.5, bar: 2.5, wrap-over: 2.5								
Load centre	c	$l/2$								
Width between legs: Cap. 2200/3000 lbs.	b_4	33.5 - 37, 37 - 44.25, 44.25 - 51.5, 49 - 56**** / 33.5 - 37, 37 - 44.25								
Fork width	e	Chisel: 4, bar: 4, wrap-over: 6.5								
Run-in length	l_x	38,1 with 45 and 42 forks								
Gangway (pallet: 47" x 31.5")	A_{st}	86.5" - tests show that 67" are enough - depends on width between straddle legs								
Free lift	h_2							7.5		
Turning angle of the wheels		210°								
Driving motor		1,2 kW 24 V speed control electronically variable								
Driving speed with/without load		Below 19.5" lift: 5/6 km/h, over 19.5" lift: 3/4 km/h								
Pump motor		1,2 kW 24 V								
Lifting speed with/without load		Cap. 2200 lbs.: 2.75" per sec./4.75" per sec., cap. 3000 lbs.: 1.5" per sec./2.75" per sec.								
Lowering speed with/without load		4.75"/2.75" per sec.				4.75" per sec./3" per sec.				
Weight lbs. (no battery)		904	946	961	970	987	1082	1098	1118	

* 3300 lbs models are only available with chisel forks - fork length options 42" and 47".
 ** Maximum lifting height 62" with 23.5" forks, maximum lifting height 95" with 31.5" forks.
 *** Reduced capacity 1650 lbs.
 **** Width between straddle legs of more than 51.5":
 Max. capacity 1760 lbs. Fork length of 60" is not recommended.



Optimum safety through transparent and impact-resistant safety screen and reduced driving speed in raised position.

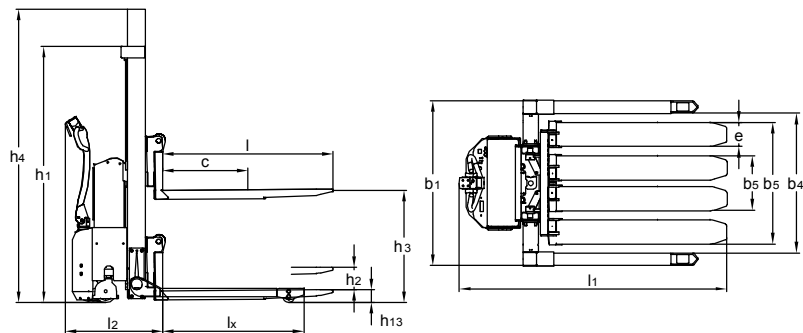

We also offer tailor-made solutions.
 Please ask for further information or visit www.interthor.com