

Stainless Steel Powered Pallet Trucks

Features

- 100% Stainless steel frame carriage, forks and undercarriage
- Available in 304L and 316L stainless steel
- Capacities 500 to 10,000
- Finishes 2B, electro polished and 35 RA
- Clean room compliant
- For Food, pharmaceutical, chemical and other demanding application
- Custom fork for lengths and widths
- cGMP Models available
- 24 Volt E and EE ratings galvanized, powder coated and epoxy steel it painted models available



Drawings

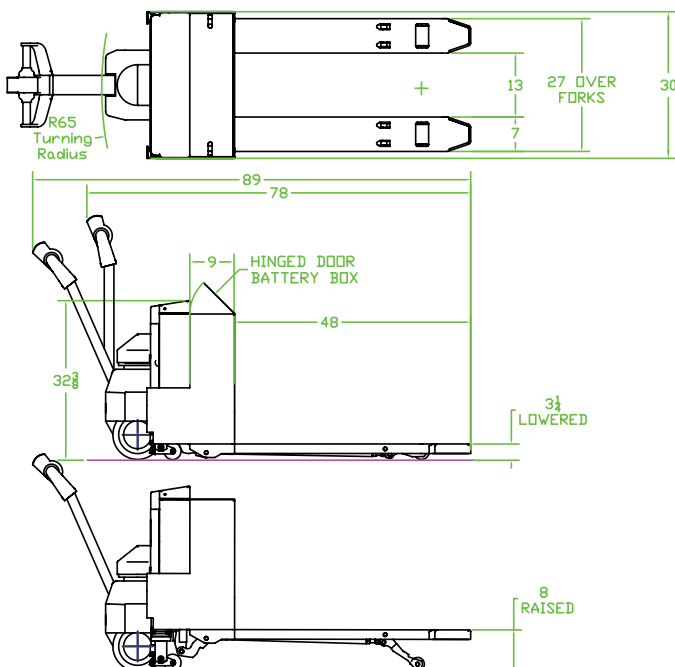

Options

- Stainless steel Platform trucks to 6,000 capacity
- Available in lift heights to 36"
- Custom sizes