

Working Harder For You



In 1876, Edwin Harrington dramatically improved the self-sustaining hoist by introducing the worm-gear design. Since then, the company he founded has earned a proud reputation for product innovations and consistent quality that our customers count on to meet their diverse requirements.

Over the years we have developed and grown by recognizing the value of our customers and responding to your needs. The daily mission of our organization is to provide you, the customer, with the highest quality in our products, service and support.

In addition to our superior products and expanded facilities, we offer a Sales and Customer Service team that is dedicated to serving you, a well qualified Engineering Department to support your technical needs and a full support staff who all know the importance of working together to provide solutions for your material handling projects.

We are working harder to be the supplier-of-choice for all of your hoist and crane applications.

Table of Contents

**TCR Air Powered Hoists
With Pendant and Cord Controls and Hook Suspension** 4-7

**TCR Air Powered Hoists
With Air Powered, Push and Geared Trolleys** 8-13

**TCR Large Capacity Air Powered Hoists
With Pendant and Cord Controls and Hook Suspension** 14-15

**TCR Air Powered Hoists
With Options** 16

**TCK Air Powered Hoists
With Pendant and Cord Controls and Hook Suspension** 17-20

**TCK Air Powered Hoists
With Air Powered, Push and Geared Trolleys** 21-25

**TCS CHEETAH Air Powered Hoists
With Pendant and Cord Controls and Hook Suspension** 26-27

**TCL Lube Free Air Powered Hoists
With Pendant and Cord Controls and Hook Suspension** 28-31

**TCL Lube Free Air Powered Hoists
With Air Powered, Push and Geared Trolleys** 32-37

**AH Mini-Cat Air Powered Hoists
With Pendant and Cord Controls and Hook Suspension** 38-41

**AH Mini-Cat Air Powered Hoists
With Manipulator Control and Hook Suspension** 42-43

**AH Mini-Cat Air Powered Hoists
With Lug Suspension** 44

**AH Mini-Cat Air Powered Hoists
With Options** 45

Technical Data 46-47

Product Code 48-49

Complete Product Offering 51

TCR Air Powered Hoists with Pendant and Cord Controls and Hook Suspension

Harrington's TCR Series air hoists offer the benefit of lifting heavier loads while maintaining low headroom and a continuous duty cycle. These hoists are best suited for use in foundries, assembly lines, construction sites and many other demanding applications.

Features and Benefits

<p>Unlimited Duty Cycle For continuous operation</p> <p>Spring-Loaded Multi-Vane Motor Design Permits very fine feathering control</p> <p>High Strength Cast Iron Housing Proven weather resistant and durable in harsh environments</p> <p>Airtight Hoist Results in efficient use of air</p> <p>Comfortable Noise Levels External muffler reduces noise level to 80dBA @ 1 yd. with no load</p> <p>Heavy Duty Self-Adjusting Brake For precise braking action</p> <p>Standard Upper & Lower Limit Stops Prevents over-travel of hook in either direction</p> <p>Overload Limiter Adjustable load limiter detects overload automatically and blocks air flow for lifting</p> <p>Wear Resistant Load Chain Grade 80, case-hardened for superior strength</p>

Standard Hoist Specifications

<p>Capacity Range 1/4 – 2 Ton (see page 14 for 10 – 25 Ton)</p> <p>Standard Lift 10' (longer lifts available)</p> <p>Standard Pendant or Cord Length Hangs approximately 4' above the hoist's fully extended bottom hook (longer lengths available)</p> <p>Air Supply Requirement 48 – 90 cfm at 60 – 90 psi</p> <p>Air Lubrication Requirement Minimum 10 to 15 drops of oil per minute (0.2 – 0.3 cc/min.)</p> <p>Air Filtration Maximum 5 micron air filter or finer required</p> <p>Air Inlet Port 1/2" NPT</p> <p>Air Supply Hose Minimum Size 1/4 – 2 Tons – 1/2"</p> <p>Operating Conditions Temperature range +14° to 140°F Humidity 85% or less</p> <p>Chain Containers Optional Canvas or Steel</p>



TCR1000P



TCR1000C2

TCR Air Powered Hoists with Pendant and Cord Controls and Hook Suspension

PENDANT MODEL—SPECIFICATIONS

Cap. (Tons)	Product Code	Standard Lift (ft)	Push Button Hose L (ft)	Up/Down Speeds (ft/min @ 90 psi)		Up/Down Air Consumption Rates (cubic ft/min @ 90 psi)		Load Chain Diameter (mm) x Chain Fall Lines	Net Weight (lbs)	Weight for Additional One Foot of Lift (lbs)
				No Load	Full Load	No Load	Full Load			
1/4	TCR250P	10	7.5	68 / 44	52 / 51	63 / 49	48 / 57	6.3 x 1	68	0.6
1/2	TCR500P		7.5	68 / 44	37 / 57	63 / 49	48 / 57	6.3 x 1	68	0.6
1	TCR1000P2		7.5	34 / 22	19 / 29	63 / 49	48 / 57	6.3 x 2	78	1.2
1	TCR1000P		7.5	37 / 22	21 / 33	62 / 53	53 / 60	7.1 x 1	77	0.8
2	TCR2000P2		7.5	19 / 11	11 / 16	62 / 53	53 / 60	7.1 x 2	88	1.5

PENDANT MODEL—DIMENSIONS

Cap. (Tons)	Product Code	Headroom C (in)	a (in)	b (in)	d (in)	e (in)	g (in)	h (in)	i (in)	j (in)
1/4	TCR250P	18.2	13.5	6.9	6.1	6.6	1.2	4.9	2.0	1.3
1/2	TCR500P	18.2	13.5	6.9	6.1	6.6	1.2	4.9	2.0	1.3
1	TCR1000P2	20.4	13.5	7.7	6.1	6.6	1.2	5.9	1.9	2.2
1	TCR1000P	18.3	13.5	6.9	6.1	6.6	1.2	4.9	2.0	1.3
2	TCR2000P2	21.8	13.5	8.0	6.1	6.6	1.2	6.0	2.0	2.3

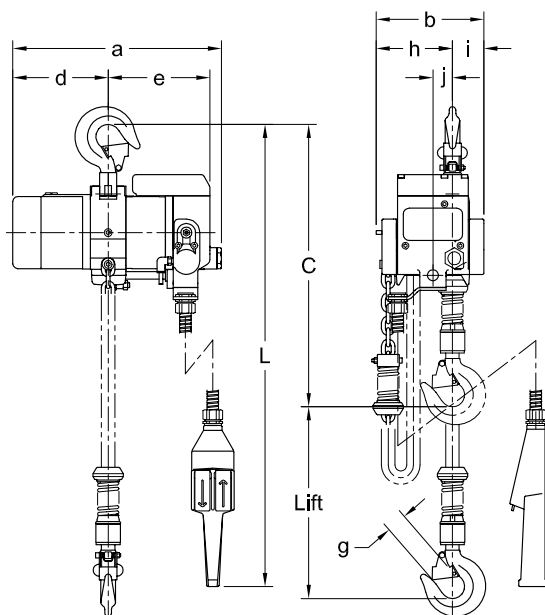

*TCR500P
Single Fall Pendant Model*

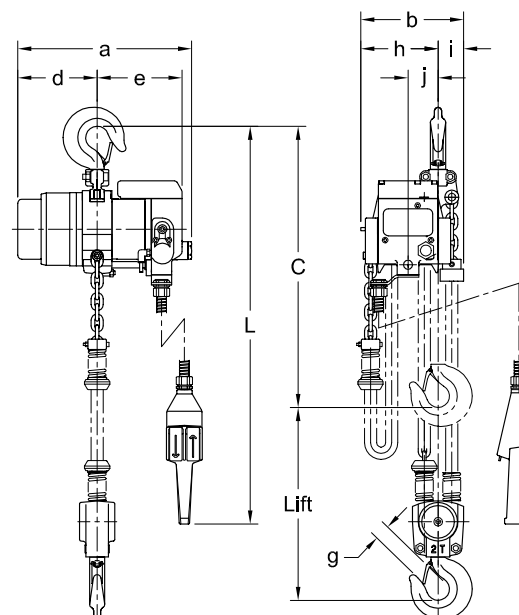

*TCR2000P2
Double Fall Pendant Model*

CORD MODEL—SPECIFICATIONS

Cap. (Tons)	Product Code	Standard Lift (ft)	Cord L (ft)	Up/Down Speeds (ft/min @ 90 psi)		Up/Down Air Consumption Rates (cubic ft/min @ 90 psi)		Load Chain Diameter (mm) x Chain Fall Lines	Net Weight (lbs)	Weight for Additional One Foot of Lift (lbs)
				No Load	Full Load	No Load	Full Load			
1/4	TCR250C	10	7.5	68 / 44	52 / 51	63 / 49	48 / 57	6.3 x 1	66	0.6
1/2	TCR500C		7.5	68 / 44	37 / 57	63 / 49	48 / 57	6.3 x 1	66	0.6
1	TCR1000C2		7.5	34 / 22	19 / 29	63 / 49	48 / 57	6.3 x 2	76	1.2
1	TCR1000C		7.5	37 / 22	21 / 33	62 / 53	53 / 60	7.1 x 1	75	0.8
2	TCR2000C2		7.5	19 / 11	11 / 16	62 / 53	53 / 60	7.1 x 2	86	1.5

CORD MODEL—DIMENSIONS

Cap. (Tons)	Product Code	Headroom C (in)	a (in)	b (in)	d (in)	e (in)	g (in)	h (in)	i (in)	j (in)	k (in)
1/4	TCR250C	18.2	13.5	6.9	6.1	6.6	1.2	4.9	2.0	1.3	8.3
1/2	TCR500C	18.2	13.5	6.9	6.1	6.6	1.2	4.9	2.0	1.3	8.3
1	TCR1000C2	20.4	13.5	7.7	6.1	6.6	1.2	5.9	1.9	2.2	8.3
1	TCR1000C	18.3	13.5	6.9	6.1	6.6	1.2	4.9	2.0	1.3	8.3
2	TCR2000C2	21.8	13.5	8.0	6.1	6.6	1.2	6.0	2.0	2.3	8.3

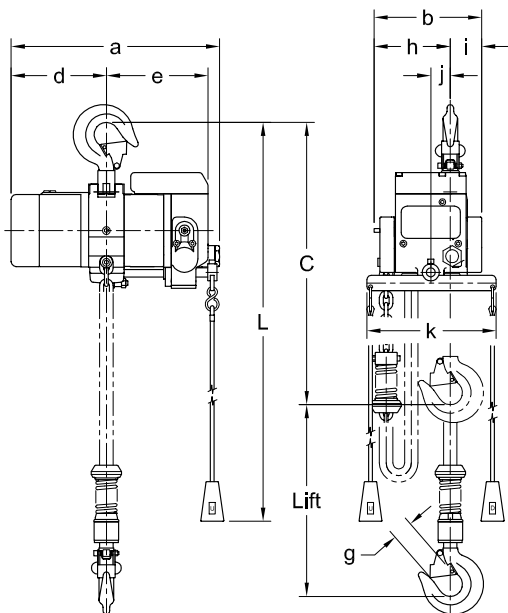

TCR500C
Single Fall Cord Model

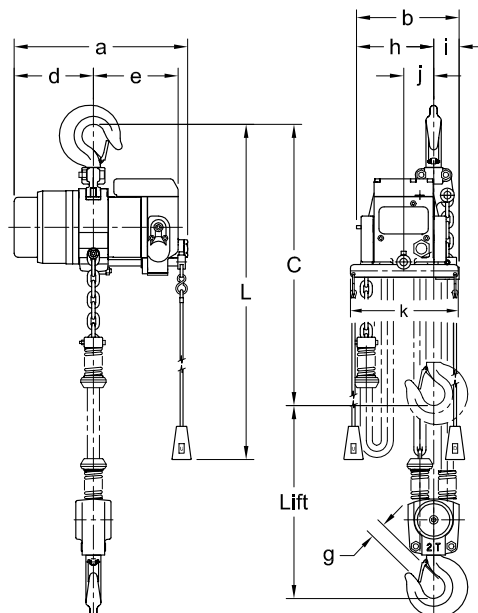

TCR2000C2
Double Fall Cord Model

TCR Air Powered Hoists with Air Powered, Push and Geared Trolleys

Harrington's TCR hoists will couple with our air powered, push or geared trolleys for added mobility. The MCR air powered trolley is the ideal choice for transporting medium to heavy loads in construction and foundry applications. The economical PT or GT manual trolleys are perfect for lighter, infrequent moves and in small workshops.

Refer to page 4 for standard hoist specifications.

Features and Benefits

Standard Hoist Specifications

<p style="text-align: center;">Air Powered Trolleys</p> <p style="text-align: center;">Unlimited Duty Cycle For continuous operation</p> <p>Spring-Loaded Multi-Vane Motor Design Permits smooth operation and controlled travel</p> <p>High Strength Cast Iron Housing Proven weather resistant and durable in harsh environments</p> <p style="text-align: center;">Internal Disc Brake Protected from harsh environments</p> <p>Drop Stops & Rubber Bumpers To ensure safe operation</p> <p style="text-align: center;">Side Guide Rollers Provide additional stability and smooth travel</p> <p style="text-align: center;">Versatile Wheels Fit flat or tapered beam flange</p> <p style="text-align: center;">Trolley Muffler Produces low noise levels</p> <p style="text-align: center;">Manual Trolleys</p> <p style="text-align: center;">Shafts Standard shafts fit wide range of beams Longer shafts available for larger beams Spacers for easy adjustments</p> <p style="text-align: center;">Wheels All steel Sealed ball bearings Fit flat or tapered beam flange</p>	<p style="text-align: center;">Air Powered Trolleys</p> <p style="text-align: center;">Capacity Range 1/4 – 2 Ton</p> <p>Control Option on Trolley/Hoist Pendant control only</p> <p style="text-align: center;">Standard Pendant Length Hangs approximately 4' above the hoist's fully extended bottom hook (longer lengths available – maximum 30')</p> <p style="text-align: center;">Air Supply Requirement 53 cfm at 60 – 90 psi</p> <p>Air Lubrication Requirement Minimum 10 to 15 drops of oil per minute (0.2 – 0.3 cc/min.)</p> <p style="text-align: center;">Air Filtration Maximum 5 micron air filter or finer required</p> <p style="text-align: center;">Air Inlet Port 3/4" NPT</p> <p>Air Supply Hose Minimum Size 1/4 – 2 Tons – 1/2"</p> <p>Operating Conditions Temperature range +14° to 140°F Humidity 85% or less</p> <p style="text-align: center;">Manual Trolleys</p> <p style="text-align: center;">Capacity Range 1/4 – 2 Ton</p> <p>Control Option on Hoist TCRP and TCRG – Pendant and cord</p> <p style="text-align: center;">Standard Hand Chain Length On geared trolleys Hangs approximately 2' less than fully extended bottom hook (longer lengths available)</p>
---	--

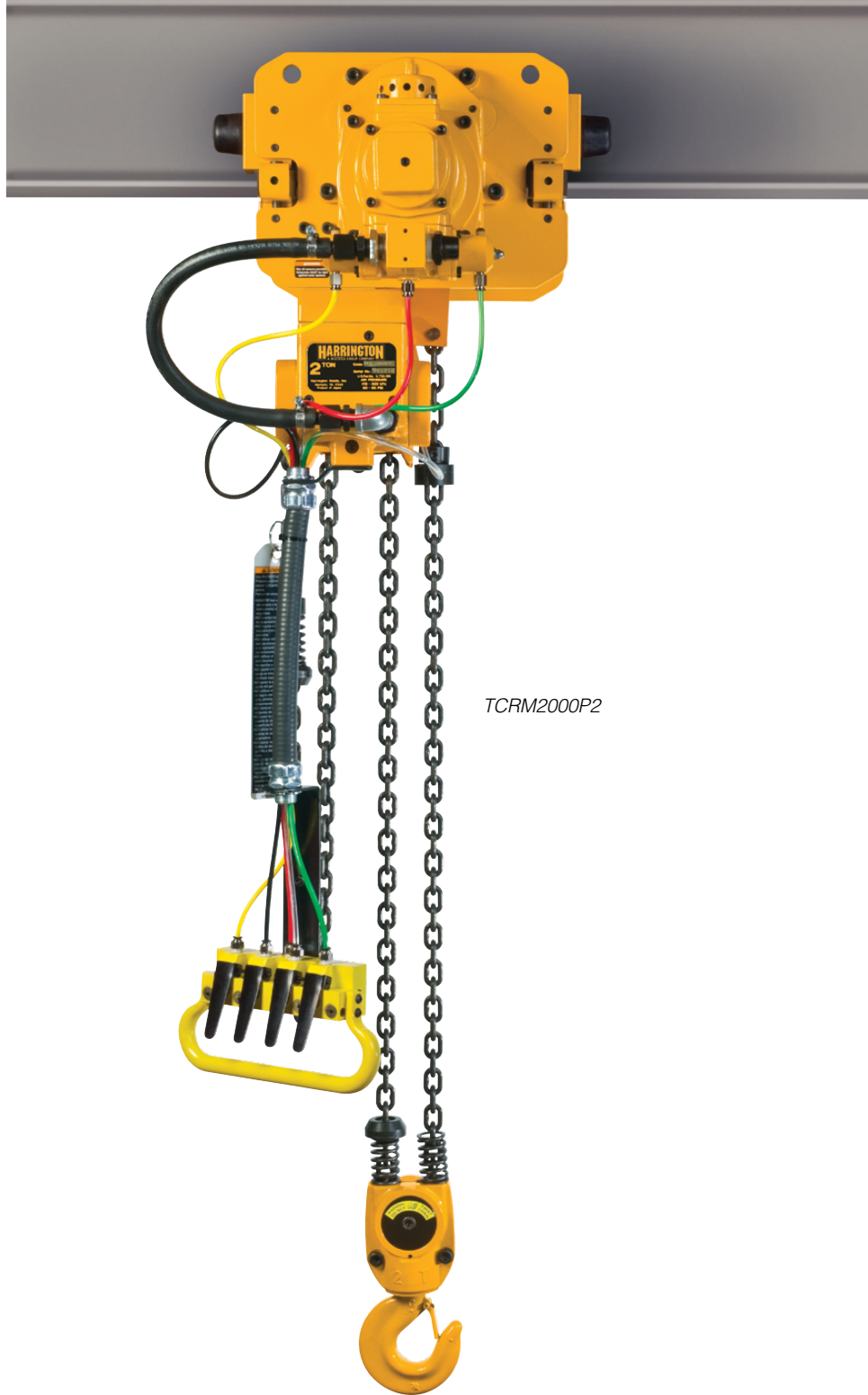

TCRM2000P2

TCR Air Powered Hoists with Air Powered, Push and Geared Trolleys

PENDANT MODEL WITH AIR POWERED TROLLEY—SPECIFICATIONS

Cap. (Tons)	Product Code	Standard Lift (ft)	Push Button Hose L (ft)	Up/Down Speeds (ft/min @ 90 psi)		Traversing Speed (ft/min)	Up/Down Air Consumption Rates (cfm @ 90 psi)			Flange Width Adjustability B (in)	Minimum Allow. Radius for Curve (in)	Load Chain Diameter (mm) x Chain Fall Lines	Net Weight (lbs)	Weight for Additional One Foot of Lift (lbs)
				No Load	Full Load		TCR		MCR					
							No Load	Full Load						
1/4	TCRM250P	10	7.4	68 / 44	52 / 51	65	63 / 49	48 / 57	53	2.28 to 5.00	137.8	6.3 x 1	170	0.6
1/2	TCRM500P			68 / 44	37 / 57		63 / 49	48 / 57	53			6.3 x 1	170	0.6
1	TCRM1000P2			34 / 22	19 / 29		63 / 49	48 / 57	53			6.3 x 2	183	1.2
1	TCRM1000P			37 / 22	21 / 33		62 / 53	53 / 60	53			7.1 x 1	209	0.8
2	TCRM2000P2			18.5 / 11	11 / 16		62 / 53	53 / 60	53	3.94 to 6.02	51.2	7.1 x 2	254	1.5

PENDANT MODEL WITH AIR POWERED TROLLEYS—DIMENSIONS

Cap. (Tons)	Product Code	Headroom C (in)	b (in)	b' (in)	d (in)	e (in)	e' (in)	g (in)	i (in)	j (in)	k (in)	m (in)	n (in)	r (in)	t (in)
1/4	TCRM250P	19.3	12.4	15.6	10.3	6.2	3.7	1.2	3.7	0.9	4.8	4.6	4.4	2.0	1.2
1/2	TCRM500P	19.3	12.4	15.6	10.3	6.2	3.7	1.2	3.7	0.9	4.8	4.6	4.4	2.0	1.2
1	TCRM1000P2	21.5	12.4	15.6	10.3	6.2	3.7	1.2	3.7	0.9	4.8	4.6	4.4	2.0	1.2
1	TCRM1000P	19.5	12.4	15.6	10.3	6.2	3.7	1.2	3.7	0.9	4.8	4.6	4.4	2.0	1.2
2	TCRM2000P2	23.3	13.4	17.4	10.5	6.9	3.9	1.2	4.9	1.3	5.0	5.1	5.5	2.8	1.7

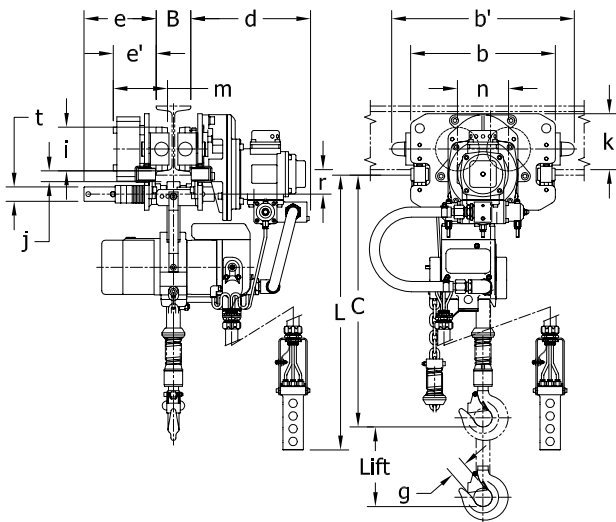

TCRM500P

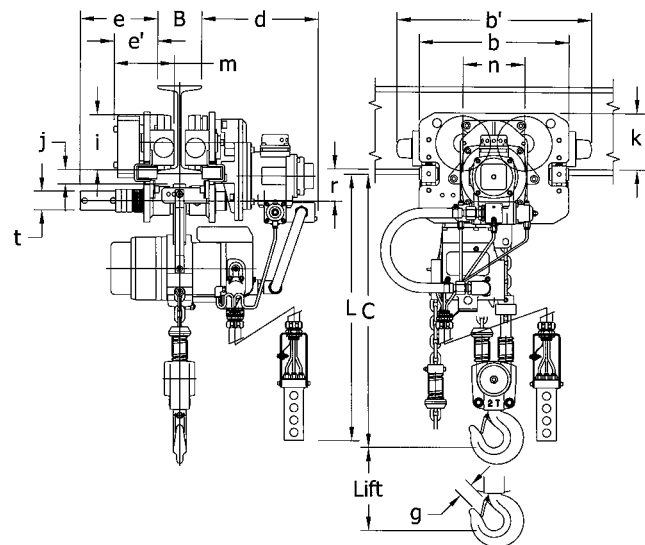

TCRM2000P2

PENDANT MODEL WITH PUSH OR GEARED TROLLEY—SPECIFICATIONS

Cap. (Tons)	Product Code	Standard Lift (ft)	Push Button Hose L (ft)	Up/Down Speeds (ft/min @ 90 psi)		Up/Down Air Consumption Rates (cubic ft/min @ 90 psi)		Flange Width Adjustability B (in)		Minimum* Allow. Radius for Curve (in)	Load Chain Diameter (mm) x Chain Fall Lines	Net Weight (lbs)	Weight for Additional One Foot of Lift (lbs)
				No Load	Full Load	No Load	Full Load	Standard	Optional				
1/4	TCRP(TCRG)250P	10	7.5	68 / 44	52 / 51	63 / 49	48 / 57	2.28 to 4.00 (2.28 to 5.00)	4.01 to 8.00 (5.01 to 8.00) OR 8.01 to 12.00	13.8 (51.2)	6.3 x 1	76 (96)	0.6 (1.2)
1/2	TCRP(TCRG)500P		7.5	68 / 44	37 / 57	63 / 49	48 / 57				6.3 x 1	76 (96)	0.6 (1.2)
1	TCRP(TCRG)1000P2		7.5	34 / 22	19 / 29	63 / 49	48 / 57	2.28 to 5.00	5.01 to 8.00 OR 8.01 to 12.00	17.7 (51.2)	6.3 x 2	94 (108)	1.2 (1.8)
1	TCRP(TCRG)1000P		7.5	37 / 22	21 / 33	62 / 53	53 / 60				7.1 x 1	91 (105)	0.8 (1.4)
2	TCRP(TCRG)2000P2		7.5	19 / 11	11 / 16	62 / 53	53 / 60	3.23 to 6.02	6.03 to 12.00	21.7 (59.1)	7.1 x 2	113 (130)	1.5 (2.1)

Figures in parenthesis are data for geared trolley
 *Minimum flange width for curved beam: 1 Ton Push and 1/8 to 1Ton Geared = 2.87 in.

CORD MODEL WITH PUSH OR GEARED TROLLEY—SPECIFICATIONS

Cap. (Tons)	Product Code	Standard Lift (ft)	Cord L (ft)	Up/Down Speeds (ft/min @ 90 psi)		Up/Down Air Consumption Rates (cubic ft/min @ 90 psi)		Flange Width Adjustability B (in)		Minimum* Allow. Radius for Curve (in)	Load Chain Diameter (mm) x Chain Fall Lines	Net Weight (lbs)	Weight for Additional One Foot of Lift (lbs)
				No Load	Full Load	No Load	Full Load	Standard	Optional				
1/4	TCRP(TCRG)250C	10	7.5	68 / 44	52 / 51	63 / 49	48 / 57	2.28 to 4.00 (2.28 to 5.00)	4.01 to 8.00 (5.01 to 8.00) OR 8.01 to 12.00	13.8 (51.2)	6.3 x 1	74 (94)	0.6 (1.2)
1/2	TCRP(TCRG)500C		7.5	68 / 44	37 / 57	63 / 49	48 / 57				6.3 x 1	73 (94)	0.6 (1.2)
1	TCRP(TCRG)1000C2		7.5	34 / 22	19 / 29	63 / 49	48 / 57	2.28 to 5.00	5.01 to 8.00 OR 8.01 to 12.00	17.7 (51.2)	6.3 x 2	91 (106)	1.2 (1.8)
1	TCRP(TCRG)1000C		7.5	37 / 22	21 / 33	62 / 53	53 / 60				7.1 x 1	89 (103)	0.8 (1.4)
2	TCRP(TCRG)2000C2		7.5	19 / 11	11 / 16	62 / 53	53 / 60	3.23 to 6.02	6.03 to 12.00	21.7 (59.1)	7.1 x 2	111 (128)	1.5 (2.1)

Figures in parenthesis are data for geared trolley
 *Minimum flange width for curved beam: 1 Ton Push and 1/8 to 1Ton Geared = 2.87 in.

TCR Air Powered Hoists with Air Powered, Push and Geared Trolleys

PENDANT AND CORD MODEL WITH PUSH TROLLEY—DIMENSIONS

Cap. (Tons)	Product Code	Headroom C (in)	a (in)	b (in)	e (in)	g (in)	h (in)	i (in)	j (in)	k (in)	m (in)	n (in)	r (in)	t (in)
1/4	TCRP250C/P	18.6	8.0	7.2	1.8	1.1	3.2	2.36	0.5	3.0	1.9	3.3	1.5	0.87
1/2	TCRP500C/P	18.6	8.0	7.2	1.8	1.1	3.2	2.36	0.5	3.0	1.9	3.3	1.5	0.87
1	TCRP1000C2/P2	21.3	9.8	9.3	2.2	1.1	4.2	2.80	0.9	3.7	2.2	4.4	2.0	0.98
1	TCRP1000C/P	19.2	9.8	9.3	2.2	1.1	4.2	2.80	1.0	3.7	2.2	4.4	2.0	0.98
2	TCRP2000C2/P2	21.9	11.8	11.0	2.7	1.1	5.0	3.35	1.0	4.4	2.8	5.2	2.4	1.26

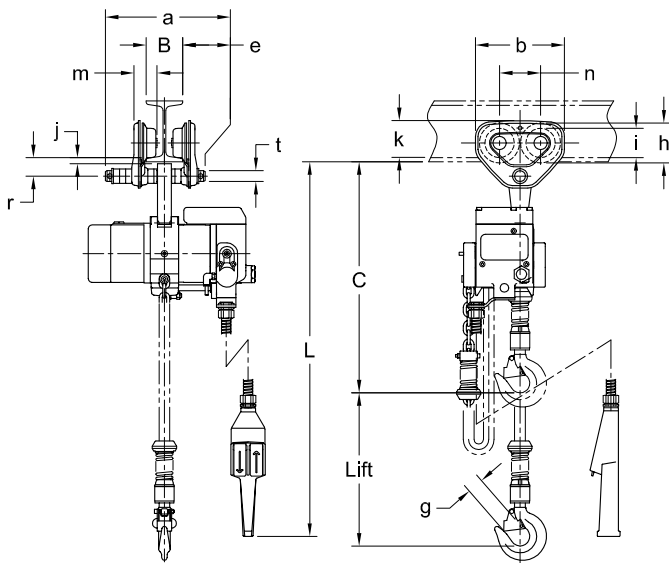

TCRP500P

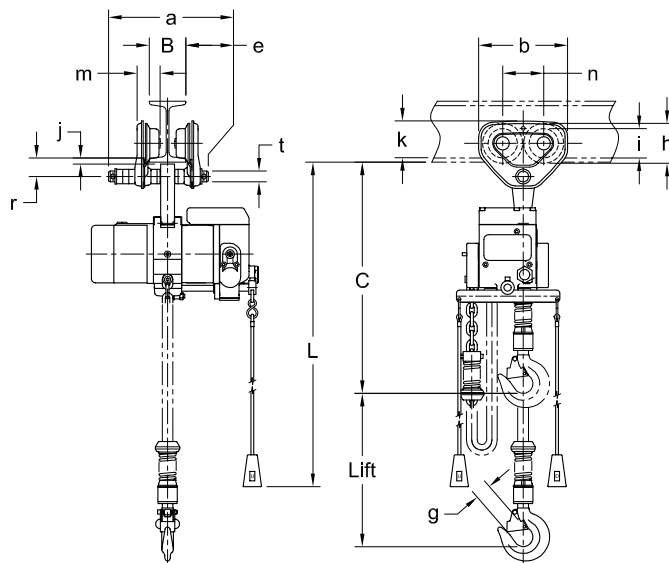

TCRP500C

PENDANT AND CORD MODEL WITH GEARED TROLLEY—DIMENSIONS

Cap. (Tons)	Product Code	Headroom C (in)	E (ft)	a (in)	b (in)	e (in)	g (in)	h (in)	i (in)	j (in)	k (in)	k' (in)	m (in)	n (in)	r (in)	t (in)	u (in)
1/4	TCRG250C/P	19.0	10.5	20.9	9.3	13.3	1.1	4.2	2.80	1.0	3.7	4.2	2.2	4.4	2.0	0.98	7.2
1/2	TCRG500C/P	19.0	10.5	20.9	9.3	13.3	1.1	4.2	2.80	1.0	3.7	4.2	2.2	4.4	2.0	0.98	7.2
1	TCRG1000C2/P2	21.3	10.5	20.9	9.3	13.3	1.1	4.2	2.80	0.9	3.7	4.2	2.2	4.4	2.0	0.98	7.2
1	TCRG1000C/P	19.2	10.5	20.9	9.3	13.3	1.1	4.2	2.80	1.0	3.7	4.2	2.2	4.4	2.0	0.98	7.2
2	TCRG2000C2/P2	21.9	10.5	24.8	11.0	13.3	1.1	5.0	3.35	1.0	4.4	4.3	2.8	5.2	2.4	1.26	7.2

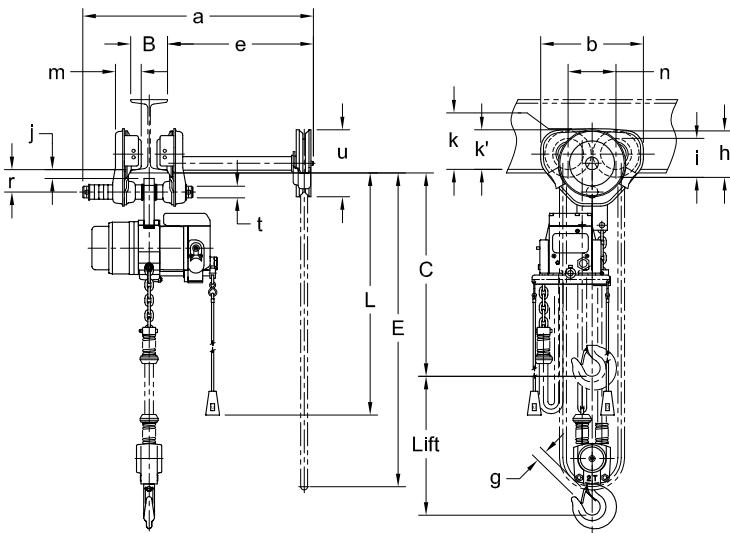
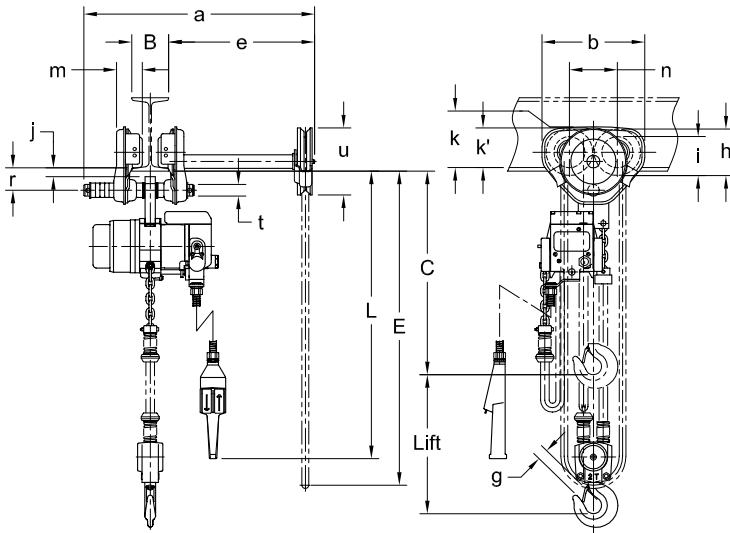

TCR Large Capacity Air Powered Hoists with Pendant and Cord Controls and Hook Suspension

Harrington's TCR large capacity air chain hoists are market tested and proven to be durable and easily repairable. These high-performance hoists have the power required for lifting very heavy material and are best suited for extreme applications including in mines, shipyards, heavy construction, rigging situations and the petrochemical industry.

Standard Hoist Specifications

Capacity Range

10 – 25 Ton

Standard Lift

10'
(longer lifts available)

Standard Pendant or Cord Length

Hangs approximately 4' above the hoist's fully extended bottom hook
(longer lengths available)

Air Supply Requirement

170 – 220 cfm at 60 – 90 psi

Air Lubrication Requirement

Minimum 10 – 15 drops of oil per minute (0.2 – 0.3 cc/min.)

Air Filtration

Maximum 5 micron air filter or finer required

Air Inlet Port

1" NPT

Air Supply Hose Minimum Size

1"

Operating Conditions

Temperature range +14° to 140°F
Humidity 85% or less



TCR10000C2

LARGE CAPACITY PENDANT MODEL—SPECIFICATIONS

Cap. (Tons)	Product Code	Standard Lift (ft)	Push Button Hose L (ft)	Up/Down Speeds (ft/min @ 90 psi)		Up/Down Air Consumption Rates (cubic ft/min @ 90 psi)		Load Chain Diameter (mm) x Chain Fall Lines	Net Weight (lbs)	Weight for Additional One Foot of Lift (lbs)
				No Load	Full Load	No Load	Full Load			
10	TCR10000P2	10	8.8	7.2 / 5.9	5.1 / 7.6	220 / 180	180 / 210	16 x 2	476	3.8
25	TCR25000P2		9.4	2.1 / 1.6	1.8 / 2.2	210 / 190	170 / 200	22 x 2	1082	7.0

LARGE CAPACITY PENDANT MODEL—DIMENSIONS

Cap. (Tons)	Product Code	Headroom C (in)	a (in)	b (in)	d (in)	e (in)	g (in)	h (in)	i (in)	j (in)
10	TCR10000P2	35.0	22	18.4	9.7	12.3	1.6	7.4	11.0	2.4
25	TCR25000P2	56.7	27.9	18.8	14.3	13.6	3.1	6.5	12.3	4.9

LARGE CAPACITY CORD MODEL—SPECIFICATIONS

Cap. (Tons)	Product Code	Standard Lift (ft)	Cord L (ft)	Up/Down Speeds (ft/min @ 90 psi)		Up/Down Air Consumption Rates (cubic ft/min @ 90 psi)		Load Chain Diameter (mm) x Chain Fall Lines	Net Weight (lbs)	Weight for Additional One Foot of Lift (lbs)
				No Load	Full Load	No Load	Full Load			
10	TCR10000C2	10	8.1	7.2 / 5.9	5.1 / 7.6	220 / 180	180 / 210	16 x 2	465	3.8
25	TCR25000C2		8.7	2.1 / 1.6	1.8 / 2.2	210 / 190	170 / 200	22 x 2	1074	7.0

LARGE CAPACITY CORD MODEL—DIMENSIONS

Cap. (Tons)	Product Code	Headroom C (in)	a (in)	b (in)	d (in)	e (in)	g (in)	h (in)	i (in)	j (in)
10	TCR10000C2	35.0	22	18.4	9.7	12.3	1.6	7.4	11.0	2.4
25	TCR25000C2	56.7	27.9	18.8	14.3	13.6	3.1	6.5	12.3	4.9

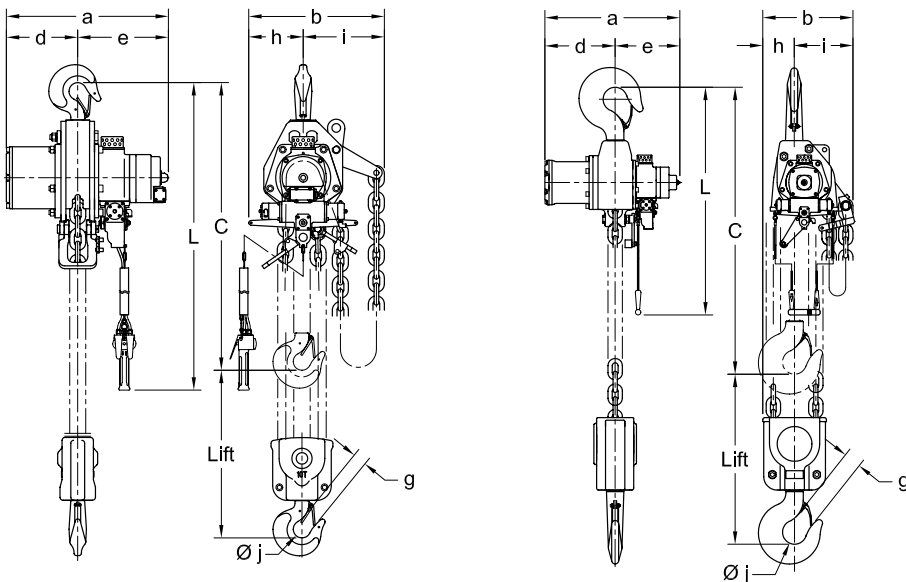

TCR10000P2

TCR25000C2

TCR Air Powered Hoists with Options

HOISTS WITH CANVAS CHAIN CONTAINERS—DIMENSIONS

Product Code	a (in)				d (in)	e (in)
	TCR	TCRM	TCRP	TCRG		
TCR250C/P	28.7	29.8	29.1	28.8	5.7	11.0
TCR500C/P	28.7	29.8	29.1	28.8	5.7	11.0
TCR1000C2/P2	28.7	29.8	29.5	29.5	5.7	12.0
TCR1000C/P	28.7	29.8	29.5	29.5	5.7	11.0
TCR2000C2/P2	29.7	30.1	29.7	29.7	5.7	12.1

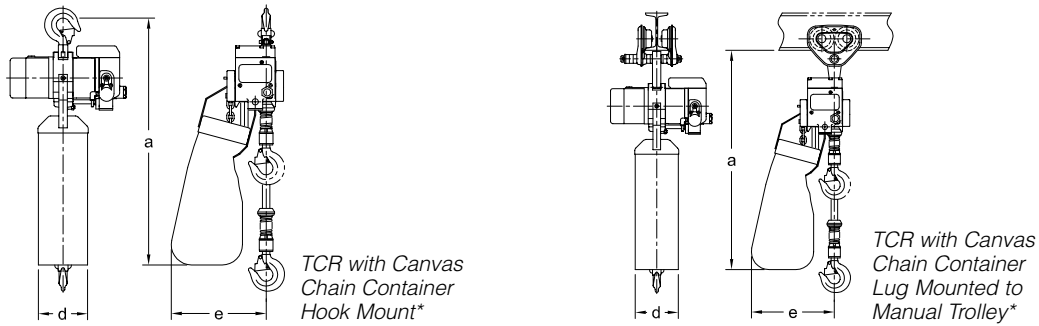

*Single fall hoist shown, double fall hoist may look different.

HOISTS WITH L, FL AND FRL—DIMENSIONS

Cap. (Tons)	Product Code	a (in)			b (in)	d (in)	e (in)	g (in)	h (in)	
		L	FL	FRL					FRL	k (in)
1/4	TCR250C/P	14.2	16.6	20.3	12.6	6.1	3.7	2.1	3.8	15.6
1/2	TCR500C/P	14.2	16.6	20.3	12.6	6.1	3.7	2.1	3.8	15.6
1	TCR1000C2/P2	14.2	16.6	20.3	12.6	6.1	3.7	2.1	3.8	15.6
1	TCR1000C/P	14.2	16.6	20.3	12.6	6.1	3.7	2.1	3.8	15.6
2	TCR2000C2/P2	14.2	16.6	20.3	12.6	6.1	3.7	2.1	3.8	16.6

L = Lubricator
 FL = Filter and Lubricator
 FRL = Filter, Regulator and Lubricator

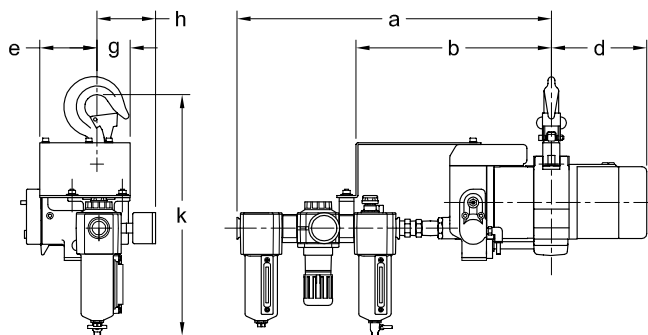

TCR with L, FL and FRL

TCK Air Powered Hoists with Pendant and Cord Controls and Hook Suspension

Harrington's TCK air powered air hoists are the best choice for low headroom and fast lifting requirements in demanding industrial settings. These hoists are extremely durable, are packed with top quality features and will far exceed workplace demands.

Features and Benefits

Unlimited Duty Cycle

For continuous operation

Spring-Loaded Multi-Vane Motor Design

Permits very fine feathering control

Cast Iron Housing

For strength and durability

Powder Coated Finish

Proven weather resistant
in harsh environments

Internal Disc Brake

Protected from harsh environments

Extremely Fast Lifting

For applications where speed is critical

Low Noise Levels

Adds to operator comfort

Overload Limiter

Adjustable load limiter detects overload
automatically and blocks air flow for lifting

Nickel-Plated Load Chain

Resistant to corrosion, abrasion and wear

Standard Hoist Specifications

Capacity Range

3 – 6 Ton

Standard Lift

10'
(longer lifts available)

Standard Pendant or Cord Length

Hangs approximately 4 ft. above the
hoist's fully extended bottom hook
(longer lengths available)

Air Supply Requirement

60 – 90 psi

Air Filtration

Maximum 5 micron air filter or finer required

Air Inlet Port

1" NPT

Air Supply Hose Minimum Size

3/4"

Air Lubrication Requirement

Minimum 10 – 15 drops of oil
per minute (0.2 – 0.3 cc/min.)

Temperature Range

+14° – 140°F

Chain Containers

Optional
Canvas or Steel

TCK Air Powered Hoists with Pendant and Cord Controls and Hook Suspension



TCK3000P

PENDANT MODEL—SPECIFICATIONS

Cap. (Tons)	Product Code	Standard Lift (ft)	Push Button Hose L (ft)	Up/Down Speeds (ft/min @ 90 psi)		Up/Down Air Consumption Rates (cubic ft/min @ 90 psi)		Load Chain Diameter (mm) x Chain Fall Lines	Net Weight (lbs)	Weight for Additional One Foot of Lift (lbs)
				No Load	w/Full Load	No Load	w/Full Load			
3	TCK3000P	10	8.6	37 / 23	18 / 38	148 / 141	124 / 152	12.5 x 1	225	2.3
6	TCK6000P2	10	8.6	18 / 12	9 / 19	148 / 141	124 / 152	12.5 x 2	295	4.6

PENDANT MODEL—DIMENSIONS

Cap. (Tons)	Product Code	Headroom C (in)	a (in)	b (in)	d (in)	e (in)	g (in)	h (in)	i (in)	j (in)
3	TCK3000P	21.1	22.7	12.3	10.4	12.2	1.3	7.4	4.9	1.3
6	TCK6000P2	30.3	22.7	14.6	10.4	12.2	1.7	9.6	5.0	3.5

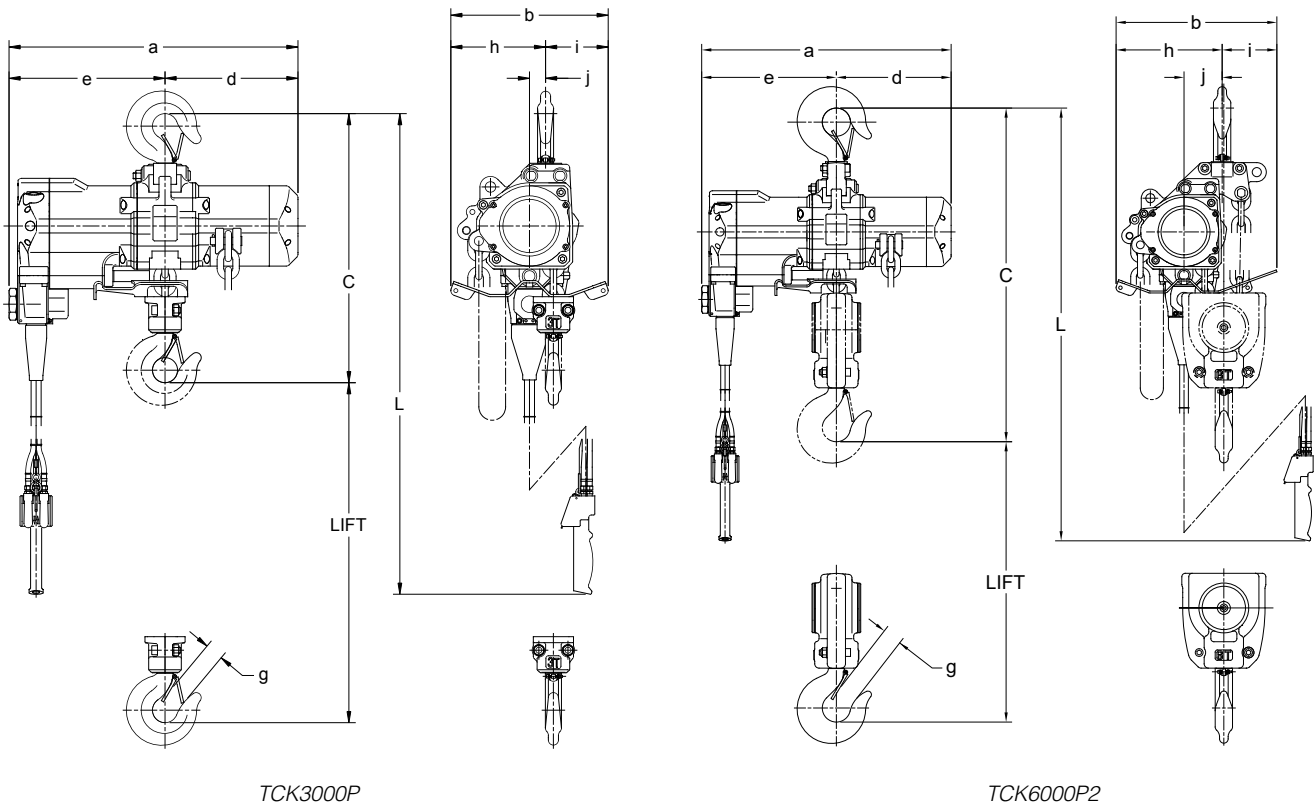

TCK Air Powered Hoists with Pendant and Cord Controls and Hook Suspension

CORD MODEL—SPECIFICATIONS

Cap. (Tons)	Product Code	Standard Lift (ft)	Cord L (ft)	Up/Down Speeds (ft/min @ 90 psi)		Up/Down Air Consumption Rates (cubic ft/min @ 90 psi)		Load Chain Diameter (mm) x Chain Fall Lines	Net Weight (lbs)	Weight for Additional One Foot of Lift (lbs)
				No Load	Full Load	No Load	Full Load			
3	TCK3000C	10	7.3	37 / 23	18 / 38	148 / 141	124 / 152	12.5 x 1	223	2.3
6	TCK6000C2	10	7.3	18 / 12	9 / 19	148 / 141	124 / 152	12.5 x 2	293	4.6

CORD MODEL—DIMENSIONS

Cap. (Tons)	Product Code	Headroom C (in)	a (in)	b (in)	d (in)	e (in)	g (in)	h (in)	i (in)	j (in)
3	TCK3000C	21.1	22.7	12.3	10.4	12.2	1.3	7.4	4.9	1.3
6	TCK6000C2	30.3	22.7	14.6	10.4	12.2	1.7	9.6	5.0	3.5

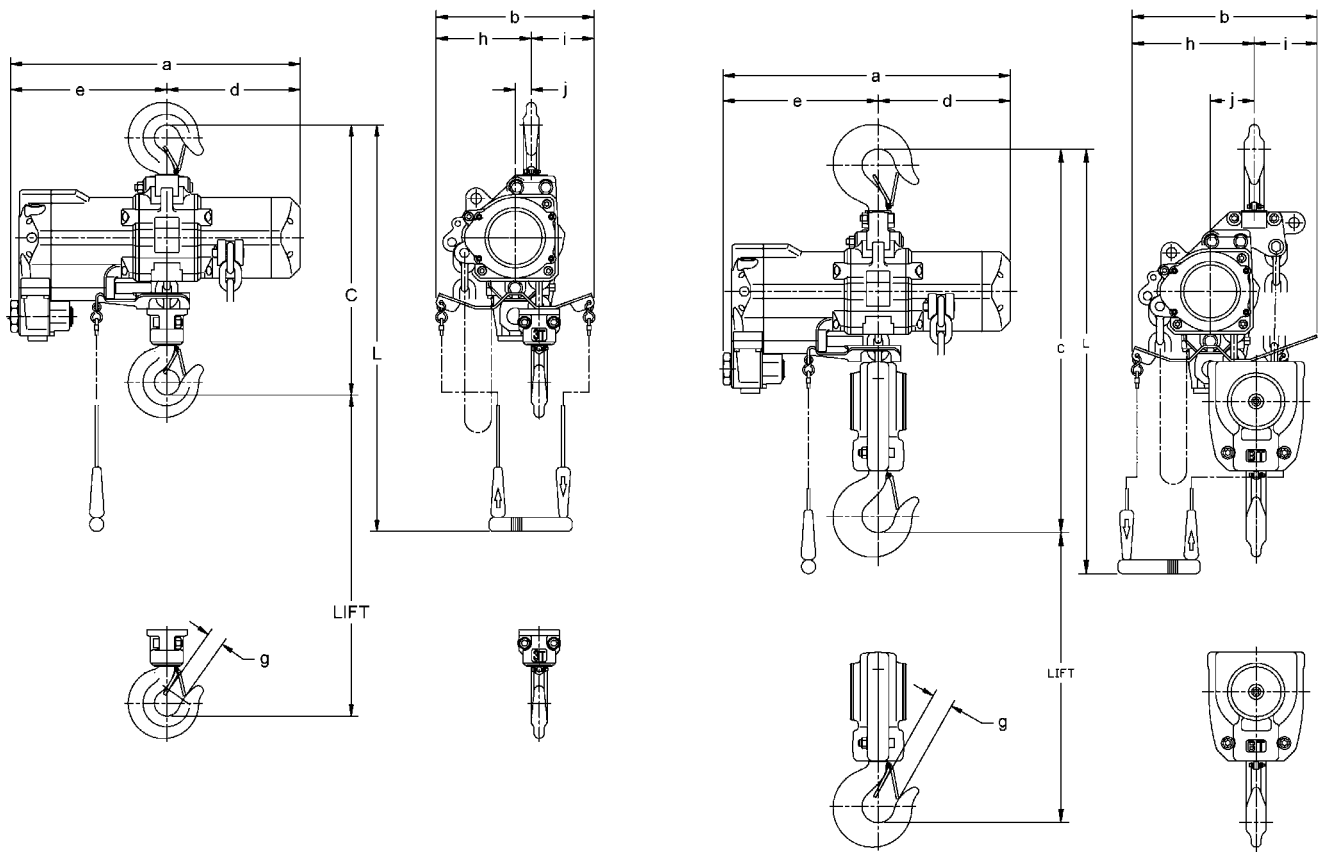

TCK3000C

TCK6000C2

TCK Air Powered Hoists with Air Powered, Push and Geared Trolleys

Harrington's TCK air powered hoists can be used with our air powered, push or geared trolleys for added mobility. The MCR air powered trolley is the ideal choice for transporting medium to heavy loads in construction and foundry applications. The economical PT or GT manual trolleys are perfect for lighter, infrequent moves and in small workshops.

Features and Benefits

Standard Hoist Specifications

<p style="text-align: center;">Air Powered Trolleys</p> <p style="text-align: center;">Unlimited Duty Cycle For continuous operation</p> <p>Spring-Loaded Multi-Vane Motor Design Permits smooth operation and controlled travel</p> <p style="text-align: center;">Cast Iron Housing For strength and durability</p> <p style="text-align: center;">Powder Coated Finish Proven weather resistant in harsh environments</p> <p style="text-align: center;">Internal Disc Brake Protected from harsh environments</p> <p style="text-align: center;">Drop Stops & Rubber Bumpers To ensure safe operation</p> <p style="text-align: center;">Side Guide Rollers Provide additional stability and smooth travel</p> <p style="text-align: center;">Versatile Wheels Fit flat or tapered beam flange</p> <p style="text-align: center;">Trolley Muffler Produces low noise levels</p> <p style="text-align: center;">Nickel-Plated Load Chain Resistant to corrosion, abrasion and wear</p> <p style="text-align: center;">Manual Trolleys</p> <p style="text-align: center;">Shafts Standard shafts fit wide range of beams Longer shafts available for larger beams Spacers for easy adjustments</p> <p style="text-align: center;">Wheels All steel Sealed ball bearings Fit flat or tapered beam flange</p>	<p style="text-align: center;">Air Powered Trolleys</p> <p style="text-align: center;">Capacity Range 3 – 6 Ton</p> <p>Control Option on Trolley/Hoist TCKM —Pendant control only</p> <p style="text-align: center;">Standard Pendant Length Hangs approximately 4' above the hoist's fully extended bottom hook (longer lengths available)</p> <p style="text-align: center;">Air Supply Requirement 53 cfm at 60 – 90 psi</p> <p style="text-align: center;">Air Filtration Maximum 5 micron air filter or finer required</p> <p style="text-align: center;">Air Inlet Port 3/4" NPT</p> <p style="text-align: center;">Air Supply Hose Minimum Size 3 – 6 Tons — 3/4"</p> <p style="text-align: center;">Air Lubrication Requirement Minimum 10 to 15 drops of oil per minute (0.2 – 0.3 cc/min.)</p> <p style="text-align: center;">Operating Conditions Temperature range +14° to 140°F Humidity 85% or less</p> <p style="text-align: center;">Manual Trolleys</p> <p style="text-align: center;">Capacity Range 3 – 6 Ton</p> <p>Control Option on Hoist TCKP and TCKG — Pendant and cord</p> <p style="text-align: center;">Standard Hand Chain Length On geared trolleys Hangs approximately 2' less than fully extended bottom hook (longer lengths available)</p>
---	--

TCK Air Powered Hoists with Air Powered, Push and Geared Trolleys



TCKM3000P



TCKP3000P



TCKG3000P

PENDANT MODEL WITH AIR POWERED TROLLEY—SPECIFICATIONS

Cap. (Tons)	Product Code	Standard Lift (ft)	Push Button Hose L (ft)	Up/Down Speeds (ft/min @ 90 psi)		Traversing Speed (ft/min)	Air Consumption Rates (cfm @ 90 psi)			Flange Width Adjustability B (in)	Minimum Allow. Radius for Curve (in)	Load Chain Diameter (mm) x Chain Fall Lines	Net Weight (lbs)	Weight for Additional One Foot of Lift (lbs)
				No Load	Full Load		TCR		MCR					
							No Load	Full Load						
3	TCKM3000P	10	8.6	37 / 23	18 / 38	65	148 / 141	124 / 152	53	3.94 to 6.02	51.2	12.5 x 1	326	2.3
6	TCKM6000P2			18 / 12	9 / 19		148 / 141	124 / 152	53	4.92 to 7.02	78.7	12.5 x 2	461	4.6

PENDANT MODEL WITH AIR POWERED TROLLEY—DIMENSIONS

Cap. (Tons)	Product Code	Headroom C (in)	b (in)	b' (in)	d (in)	e (in)	e' (in)	g (in)	i (in)	j (in)	k (in)	m (in)	n (in)	r (in)	t (in)
3	TCKM3000P	29.5	13.4	17.4	10.5	6.9	3.9	1.3	4.9	1.4	5.0	5.1	5.5	2.8	1.7
6	TCKM6000P2	34.1	15.7	19.8	10.8	8.1	4.3	1.7	5.5	1.4	5.5	5.7	6.1	3.9	2.3

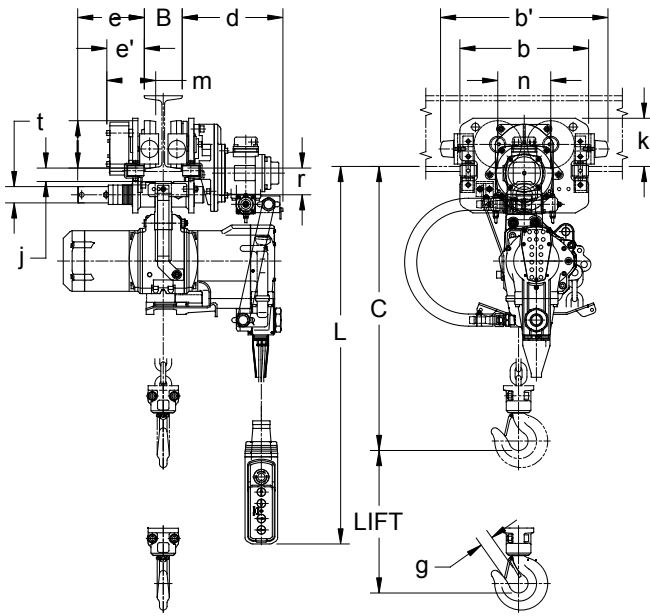

TCKM3000P

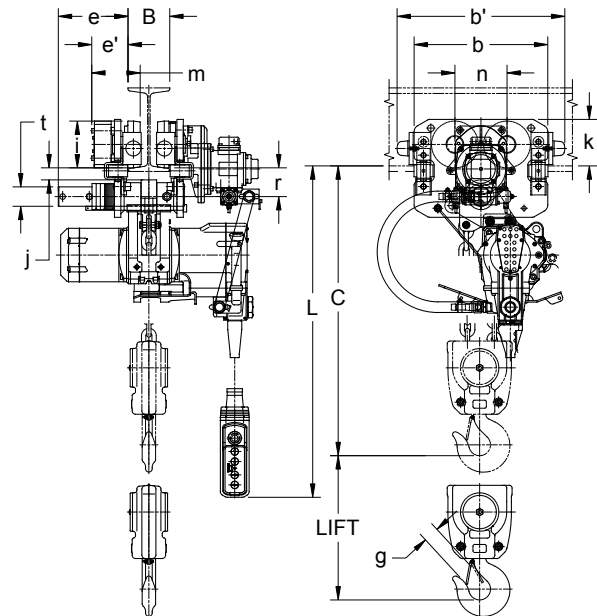

TCKM6000P2

TCK Air Powered Hoists with Air Powered, Push and Geared Trolleys

PENDANT MODEL WITH PUSH OR GEARED TROLLEY—SPECIFICATIONS

Cap. (Tons)	Product Code	Standard Lift (ft)	Push Button Hose L (ft)	Up/Down Speeds (ft/min @ 90 psi)		Up/Down Air Consumption Rates (cubic ft/min @ 90 psi)		Flange Width Adjustability B (in)		Minimum* Allow. Radius for Curve (in)	Load Chain Diameter (mm) x Chain Fall Lines	Net Weight (lbs)	Weight for Additional One Foot of Lift (lbs)
				No Load	Full Load	No Load	Full Load	Standard	Optional				
3	TCKP(TCKG)3000P	10	8.6	37 / 23	18 / 38	148 / 141	124 / 152	3.23 to 6.02	6.03 to 12.00	25.6 (66.9)	12.5 x 1	271 (287)	2.3 (2.9)
6	TCKP(TCKG)6000P2		8.6	18 / 12	9 / 19	148 / 141	124 / 152	5.50 to 8.66	8.67 to 12.00	118.1	12.5 x 2	507 (553)	4.6 (5.2)

Figures in parenthesis are data for geared trolley

*Minimum flange width for curved beam: 3 Ton Push and Geared = 3.50 in.

CORD MODEL WITH PUSH OR GEARED TROLLEY—SPECIFICATIONS

Cap. (Tons)	Product Code	Standard Lift (ft)	Cord L (ft)	Up/Down Speeds (ft/min @ 90 psi)		Up/Down Air Consumption Rates (cubic ft/min @ 90 psi)		Flange Width Adjustability B (in)		Minimum* Allow. Radius for Curve (in)	Load Chain Diameter (mm) x Chain Fall Lines	Net Weight (lbs)	Weight for Additional One Foot of Lift (lbs)
				No Load	Full Load	No Load	Full Load	Standard	Optional				
3	TCKP(TCKG)3000C	10	7.3	37 / 23	18 / 38	148 / 141	124 / 152	3.23 to 6.02	6.03 to 12.00	25.6 (66.9)	12.5 x 1	269 (284)	2.3 (2.9)
6	TCKP(TCKG)6000C2		7.3	18 / 12	9 / 19	148 / 141	124 / 152	5.50 to 8.66	8.67 to 12.00	118.1	12.5 x 2	505 (551)	4.6 (5.2)

Figures in parenthesis are data for geared trolley

*Minimum flange width for curved beam: 3 Ton Push and Geared = 3.50 in.

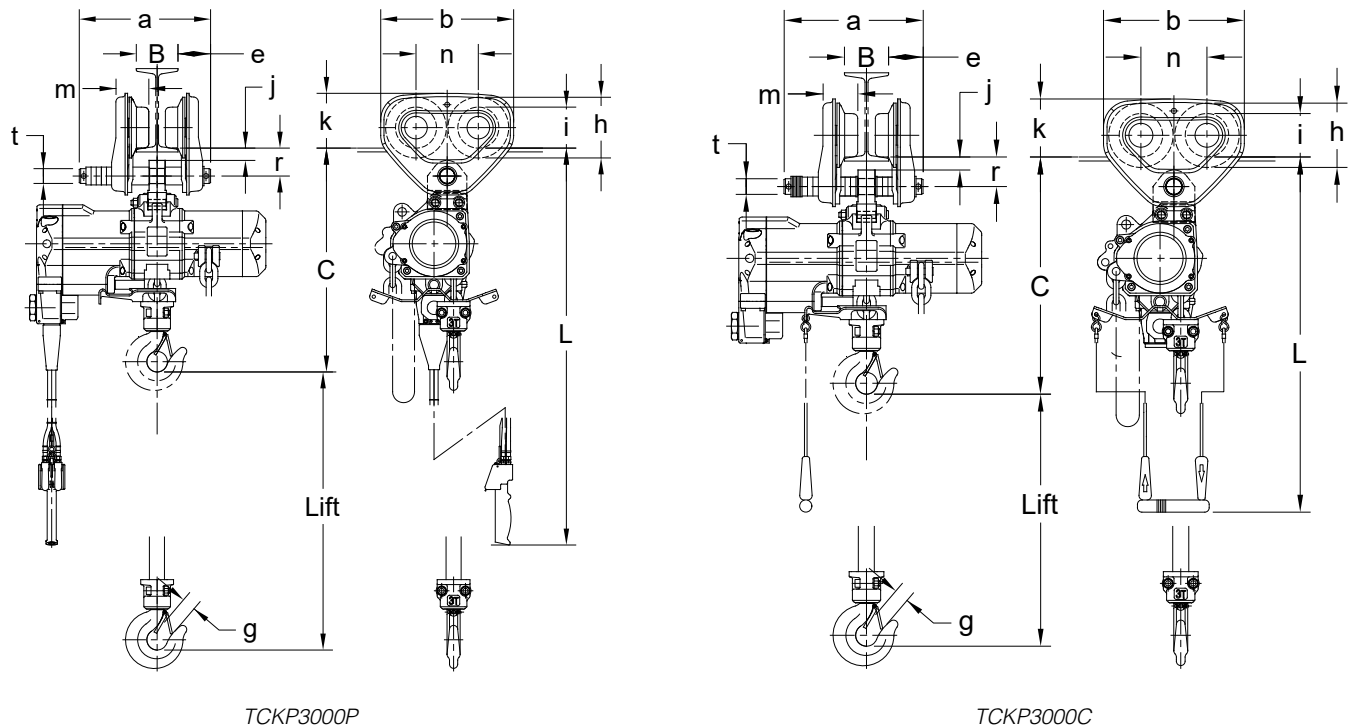

TCKP3000P

TCKP3000C

PENDANT AND CORD MODEL WITH PUSH TROLLEY—DIMENSIONS

Cap. (Tons)	Product Code	Headroom C (in)	a (in)	b (in)	e (in)	g (in)	h (in)	i (in)	j (in)	k (in)	m (in)	n (in)	r (in)	t (in)
3	TCKP3000C/P	21.5	12.6	12.8	3.1	1.3	5.8	3.94	1.2	5.3	3.1	6.0	2.7	1.42
6	TCKP6000C2/P2	33.4	17.6	18.9	4.1	1.7	7.3	6.10	3.5	6.7	3.4	7.7	6.0	2.76

PENDANT AND CORD MODEL WITH GEARED TROLLEY—DIMENSIONS

Cap. (Tons)	Product Code	Headroom C (in)	E (ft)	a (in)	b (in)	e (in)	g (in)	h (in)	i (in)	j (in)	k (in)	k' (in)	m (in)	n (in)	r (in)	t (in)	u (in)
3	TCKG3000C/P	21.5	9.8	31.2	12.8	15.9	1.3	5.8	3.94	1.2	5.3	4.5	3.1	6.0	2.7	1.42	7.2
6	TCKG6000C2/P2	33.4	10.8	29.7	18.9	14.6	1.7	7.3	6.10	3.4	6.7	6.5	3.4	7.7	6.0	2.76	8.4

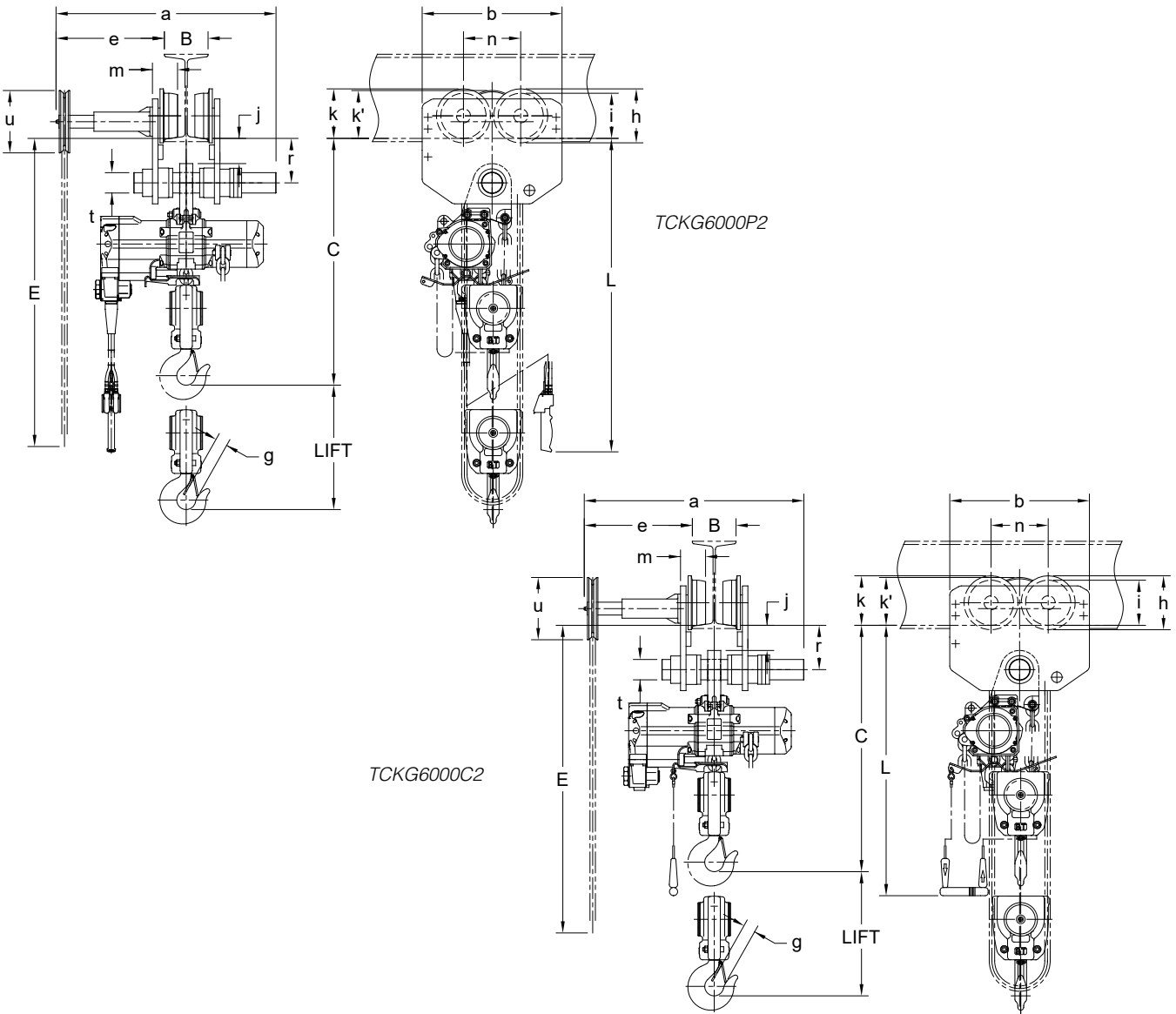

TCS CHEETAH Air Powered Hoists with Pendant and Cord Controls and Hook Suspension

TCS CHEETAH air hoists have extremely fast and uniquely adjustable lifting and lowering speeds. These hoists are lightweight, compact and have outstanding feathering ability making them a perfect fit for fast-paced assembly line and workstation crane applications.



Features and Benefits

<p>Unlimited Duty Cycle For continuous operation</p> <p>Spring-Loaded Multi-Vane Motor Design Permits very fine feathering control</p> <p>Extremely Fast Lifting For applications where speed is critical</p> <p>Extremely Compact & Lightweight Body Cast aluminum body allows for easy operation, transportation and storage</p> <p>External Speed Adjustment Screw No tools required to set specific speeds</p> <p>Adjustable Lifting and Lowering Speeds Increases production capabilities</p> <p>Heavy-duty Disc Motor Brake System For reliable load support</p> <p>Low Noise Levels Adds to operator comfort</p> <p>Nickel Plated Load Chain Resistant to corrosion, abrasion and wear</p>
--

Standard Hoist Specifications

<p>Capacity Range 1/4 – 1 Ton</p> <p>Standard Lift 10' (longer lifts available)</p> <p>Standard Pendant or Cord Length Hangs approximately 4' above the hoist's fully extended bottom hook (longer lengths available)</p> <p>Air Supply Requirement 60 – 90 psi</p> <p>Air Lubrication Requirement Minimum 10 to 15 drops of oil per minute (0.2 – 0.3 cc/min.)</p> <p>Air Filtration Maximum 5 micron air filter or finer required</p> <p>Air Inlet Port 1/2" NPT</p> <p>Air Supply Hose Minimum Size 1/2"</p> <p>Temperature Range +14° – 140°F</p> <p>Chain Containers Optional Canvas or Steel</p>
--



TCS PENDANT MODEL—SPECIFICATIONS

Cap. (Tons)	Product Code	Standard Lift (ft)	Push Button Hose L (ft)	Up/Down Speeds (ft/min @ 90 psi)		Up/Down Air Consumption Rates (cubic ft/min @ 90 psi)		Load Chain Diameter (mm) x Chain Fall Lines	Net Weight (lbs)	Weight for Additional One Foot of Lift (lbs)
				No Load	Full Load	No Load	Full Load			
1/4	TCS250P	10	8.1	207 / 125	112 / 207	74 / 64	60 / 71	6.3 x 1	46	0.6
1/2	TCS500P	10	8.1	108 / 62	56 / 112	74 / 64	60 / 71	6.3 x 1	46	0.6
1	TCS1000P2	10	8.1	54 / 31	28 / 56	74 / 64	60 / 71	6.3 x 2	60	1.2

TCS PENDANT MODEL—DIMENSIONS

Cap. (Tons)	Product Code	Headroom C (in)	a (in)	b (in)	d (in)	e (in)	g (in)	h (in)	i (in)	j (in)
1/4	TCS250P	16.3	14.4	6.6	6.4	8.0	1.0	4.4	2.2	1.0
1/2	TCS500P	16.3	14.4	6.6	6.4	8.0	1.0	4.4	2.2	1.0
1	TCS1000P2	18.0	14.4	9.0	6.4	8.0	1.1	6.3	2.7	1.9

TCS CORD MODEL—SPECIFICATIONS

Cap. (Tons)	Product Code	Standard Lift (ft)	Cord L (ft)	Up/Down Speeds (ft/min @ 90 psi)		Up/Down Air Consumption Rates (cubic ft/min @ 90 psi)		Load Chain Diameter (mm) x Chain Fall Lines	Net Weight (lbs)	Weight for Additional One Foot of Lift (lbs)
				No Load	Full Load	No Load	Full Load			
1/4	TCS250C	10	7.3	207 / 125	112 / 207	74 / 64	60 / 71	6.3 x 1	44	0.6
1/2	TCS500C	10	7.3	108 / 62	56 / 112	74 / 64	60 / 71	6.3 x 1	44	0.6
1	TCS1000C2	10	7.3	54 / 31	28 / 56	74 / 64	60 / 71	6.3 x 2	58	1.2

TCS CORD MODEL—DIMENSIONS

Cap. (Tons)	Product Code	Headroom C (in)	a (in)	b (in)	d (in)	e (in)	g (in)	h (in)	i (in)	j (in)
1/4	TCS250C	16.3	14.4	8.7	6.4	8.0	1.0	5.3	3.3	1.0
1/2	TCS500C	16.3	14.4	8.7	6.4	8.0	1.0	5.3	3.3	1.0
1	TCS1000C2	18.0	14.4	9.0	6.4	8.0	1.1	6.3	2.7	1.9

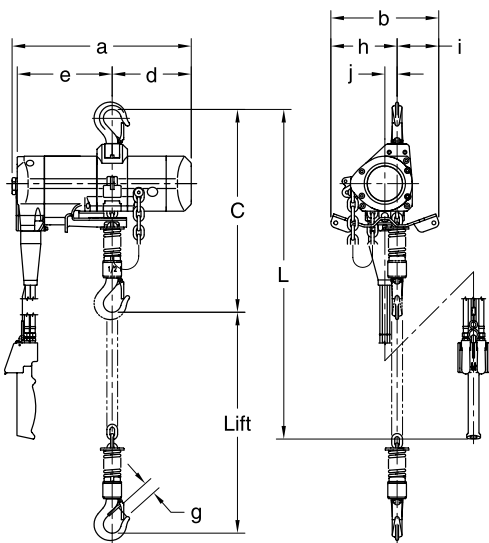

TCS250P
Single Fall Pendant Model

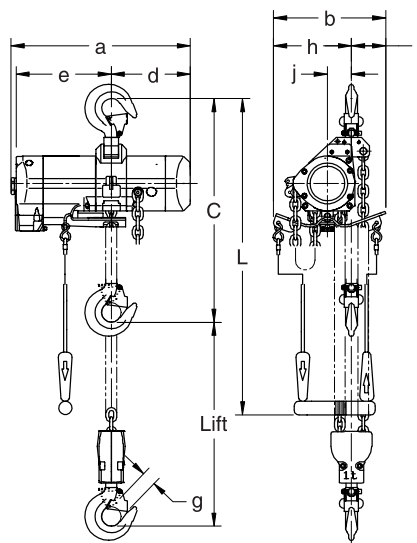

TCS1000C2
Double Fall Cord Model

TCL Lube Free Air Powered Hoists with Pendant and Cord Controls and Hook Suspension

Harrington's TCL Series lube free air hoists are able to operate without air supply lubrication which leaves the surrounding environment free of oil mist from the air exhaust. Our TCL series hoists are recommended for use in any area where oil mist cannot be tolerated such as in food, chemical or pharmaceutical industries. These hoists feature precise load positioning with either pendant or cord control.

Features and Benefits

<p>Unlimited Duty Cycle For continuous operation</p> <p>Spring-Loaded Multi-Vane Motor Design Permits very fine feathering control</p> <p>Extremely Fast Lifting For applications where speed is critical</p> <p>Low Noise Levels Adds to operator comfort</p> <p>Nickel-Plated Load Chain Resistant to corrosion, abrasion and wear</p> <p>Lubrication Free For applications where a clean environment is needed</p> <p>1/4 – 1 Ton Capacities</p> <p>Extremely Compact & Lightweight Body Cast aluminum body allows for easy operation, transportation and storage</p> <p>External Speed Adjustment Screw No tools required to set specific speeds</p> <p>Adjustable Lifting and Lowering Speeds Increases production capabilities</p> <p>Heavy-duty Disc Motor Brake System For reliable load support</p> <p>3 – 6 Ton Capacities</p> <p>Overload Limiter Adjustable load limiter detects overload automatically and blocks air flow for lifting</p> <p>Cast Iron Housing For strength and durability</p> <p>Powder Coated Finish Proven weather resistant in harsh environments</p> <p>Internal Disc Brake Protected from harsh environments</p>
--

Standard Hoist Specifications

<p>Capacity Range 1/4 – 6 Ton</p> <p>Standard Lift 10' (longer lifts available)</p> <p>Standard Pendant or Cord Length Hangs approximately 4 ft. above the hoist's fully extended bottom hook (longer lengths available)</p> <p>Air Supply Requirement 60 – 90 psi</p> <p>Air Filtration Maximum 5 micron air filter or finer required</p> <p>Air Inlet Port 1/4 – 1 Tons – 1/2" NPT 3 – 6 Tons – 1" NPT</p> <p>Air Supply Hose Minimum Size 1/4 – 1 Tons – 1/2" 3 – 6 Tons – 3/4"</p> <p>Temperature Range +14° – 140°F</p> <p>Chain Containers Optional Canvas or Steel</p>
--



TCL1000P2

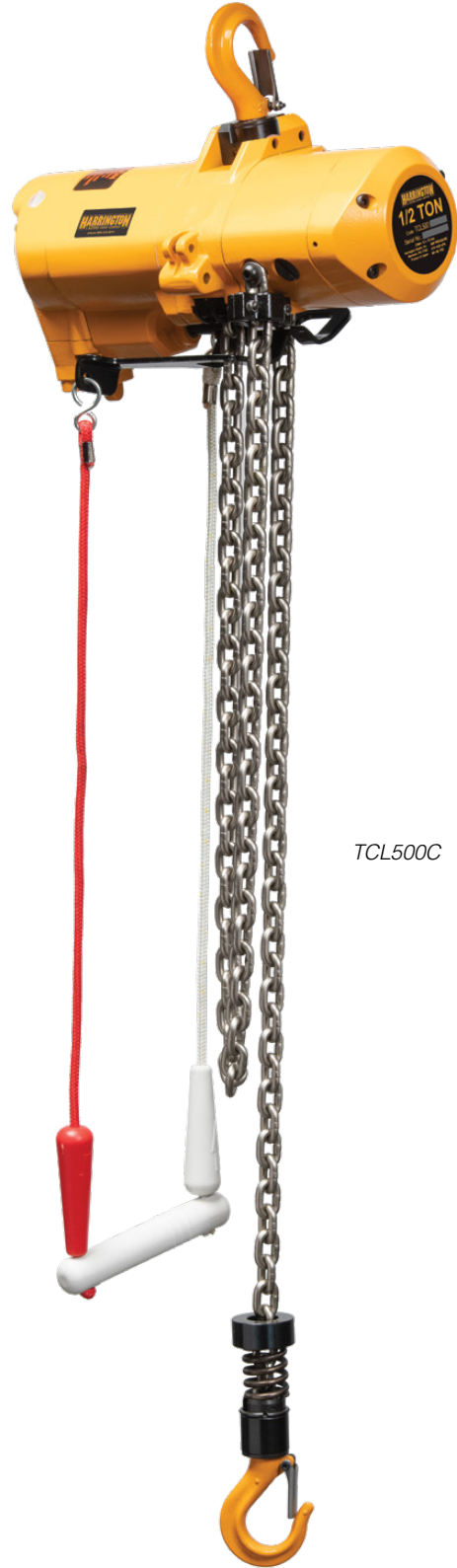

TCL500C

TCL Lube Free Air Powered Hoists with Pendant and Cord Controls and Hook Suspension

PENDANT MODEL—SPECIFICATIONS

Cap. (Tons)	Product Code	Standard Lift (ft)	Push Button Hose L (ft)	Up/Down Speeds (ft/min @ 90 psi)		Up/Down Air Consumption Rates (cubic ft/min @ 90 psi)		Load Chain Diameter (mm) x Chain Fall Lines	Net Weight (lbs)	Weight for Additional One Foot of Lift (lbs)
				No Load	Full Load	No Load	Full Load			
1/4	TCL250P	10	8.2	151 / 105	85 / 144	64 / 57	57 / 64	6.3 x 1	46	0.6
1/2	TCL500P			79 / 53	43 / 79	64 / 57	57 / 64	6.3 x 1	46	0.6
1	TCL1000P2			39 / 26	21 / 39	64 / 57	57 / 64	6.3 x 2	60	1.2
3	TCL3000P	8.6	8.6	24 / 14	10 / 22	131 / 124	106 / 141	12.5 x 1	225	2.3
6	TCL6000P2			12 / 7.2	4.9 / 11	131 / 124	106 / 141	12.5 x 2	295	4.6

PENDANT MODEL—DIMENSIONS

Cap. (Tons)	Product Code	Headroom C (in)	a (in)	b (in)	d (in)	e (in)	g (in)	h (in)	i (in)	j (in)
1/4	TCL250P	16.3	14.4	6.6	6.4	8.0	1.0	4.4	2.2	1.0
1/2	TCL500P	16.3	14.4	6.6	6.4	8.0	1.0	4.9	2.2	1.0
1	TCL1000P2	18.0	14.4	9.0	6.4	8.0	1.1	6.3	2.7	1.9
3	TCL3000P	21.1	22.7	12.3	10.4	12.2	1.3	7.4	4.9	1.3
6	TCL6000P2	30.3	22.7	14.6	10.4	12.2	1.7	9.6	5.0	3.5

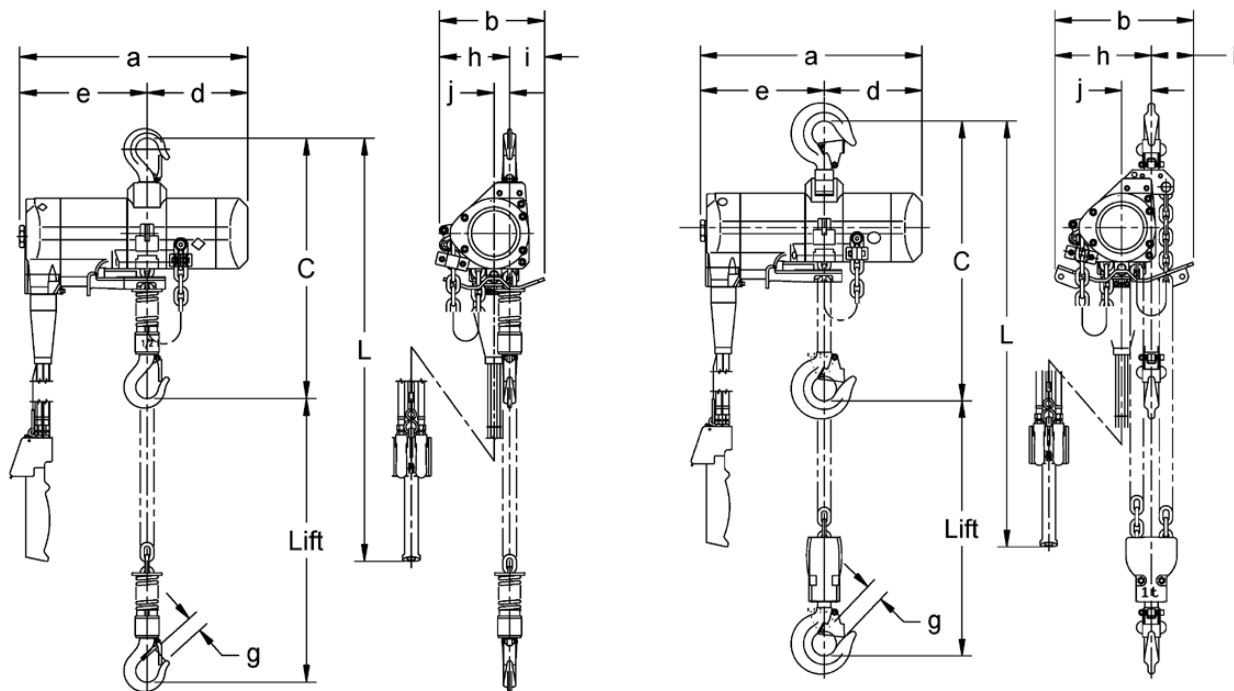

TCL500P

TCL1000P2

CORD MODEL—SPECIFICATIONS

Cap. (Tons)	Product Code	Standard Lift (ft)	Cord L (ft)	Up/Down Speeds (ft/min @ 90 psi)		Up/Down Air Consumption Rates (cubic ft/min @ 90 psi)		Load Chain Diameter (mm) x Chain Fall Lines	Net Weight (lbs)	Weight for Additional One Foot of Lift (lbs)
				No Load	Full Load	No Load	Full Load			
1/4	TCL250C	10	7.3	151 / 105	85 / 144	64 / 57	57 / 64	6.3 x 1	44	0.6
1/2	TCL500C			79 / 53	43 / 79	64 / 57	57 / 64	6.3 x 1	44	0.6
1	TCL1000C2			39 / 26	21 / 39	64 / 57	57 / 64	6.3 x 2	58	1.2
3	TCL3000C			24 / 14	10 / 22	131 / 124	106 / 141	12.5 x 1	223	2.3
6	TCL6000C2			12 / 7.2	4.9 / 11	131 / 124	106 / 141	12.5 x 2	293	4.6

CORD MODEL—DIMENSIONS

Cap. (Tons)	Product Code	Headroom C (in)	a (in)	b (in)	d (in)	e (in)	g (in)	h (in)	i (in)	j (in)
1/4	TCL250C	16.3	14.4	8.7	6.4	8.0	1.0	5.3	3.3	1.0
1/2	TCL500C	16.3	14.4	8.7	6.4	8.0	1.0	5.3	3.3	1.0
1	TCL1000C2	18.0	14.4	9.0	6.4	8.0	1.1	6.3	2.7	1.9
3	TCL3000C	21.1	22.7	12.3	10.4	12.2	1.3	7.4	4.9	1.3
6	TCL6000C2	30.3	22.7	14.6	10.4	12.2	1.7	9.6	5.0	3.5

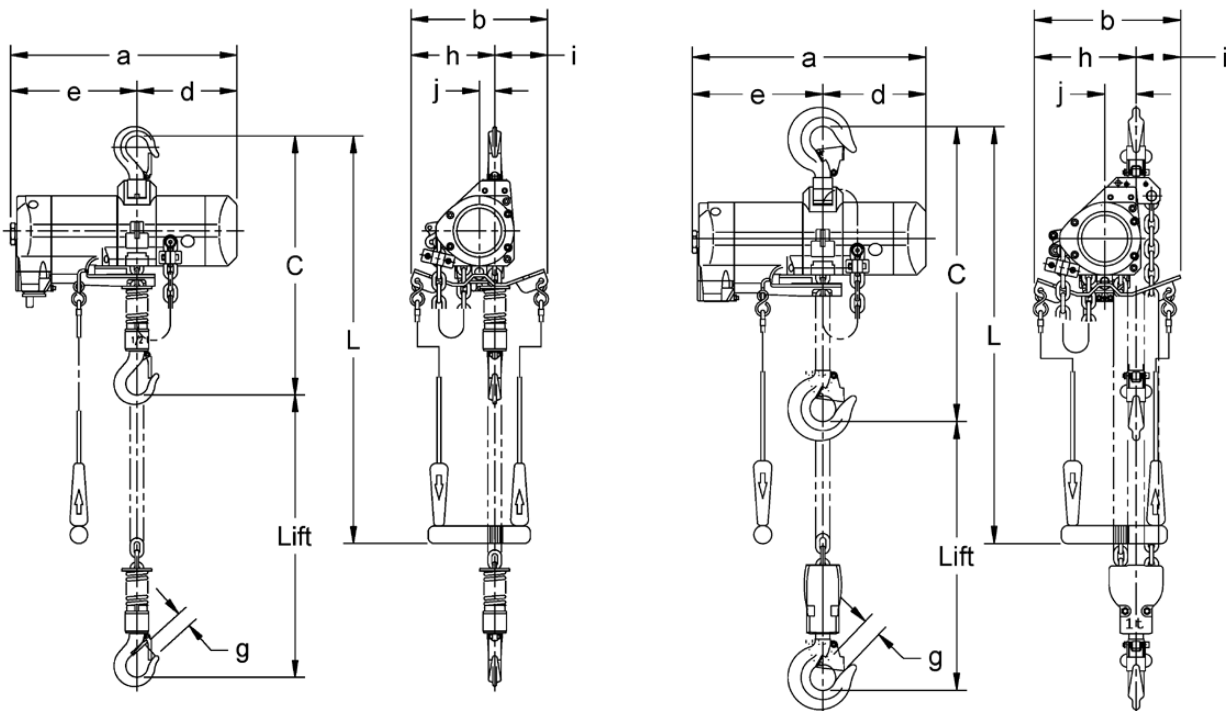

TCL500C

TCL1000C2

TCL Lube Free Air Powered Hoists with Air Powered, Push and Geared Trolleys

For added mobility, add Harrington's MCL air powered trolley to our TCL lube free hoists to easily transport medium to heavy loads. You can also mount these hoists to our PT push trolley or GT geared trolley for lighter or more infrequent moves.

Features and Benefits

Standard Hoist Specifications

<p>Air Powered Trolleys</p> <p>Unlimited Duty Cycle For continuous operation</p> <p>Spring-Loaded Multi-Vane Motor Design Permits smooth operation and controlled travel</p> <p>Drop Stops & Rubber Bumpers To ensure safe operation</p> <p>Side Guide Rollers Provide additional stability and smooth travel</p> <p>Versatile Wheels Fit flat or tapered beam flange</p> <p>Trolley Muffler Produces low noise levels</p> <p>Nickel-Plated Load Chain Resistant to corrosion, abrasion and wear</p> <p>Lubrication Free For applications where a clean environment is needed</p> <p>1/4 – 1 Ton Capacities</p> <p>Extremely Compact & Lightweight Body Cast aluminum body allows for easy operation, transportation and storage</p> <p>3 – 6 Ton Capacities</p> <p>Cast Iron Housing For strength and durability</p> <p>Powder Coated Finish Proven weather resistant in harsh environments</p> <p>Internal Disc Brake Protected from harsh environments</p> <p>Manual Trolleys</p> <p>Shafts Standard shafts fit wide range of beams Longer shafts available for larger beams Spacers for easy adjustments</p> <p>Wheels All steel Sealed ball bearings Fit flat or tapered beam flange</p>	<p>Air Powered Trolleys</p> <p>Capacity Range 1/4 – 6 Ton</p> <p>Control Option on Trolley/Hoist TCLM – Pendant control only</p> <p>Standard Pendant Length Hangs approximately 4' above the hoist's fully extended bottom hook (longer lengths available)</p> <p>Air Supply Requirement 53 cfm at 60 – 90 psi</p> <p>Air Filtration Maximum 5 micron air filter or finer required</p> <p>Air Inlet Port 3/4" NPT</p> <p>Air Supply Hose Minimum Size 1/4 – 2 Tons – 1/2" 3 – 6 Tons – 3/4"</p> <p>Operating Conditions Temperature range +14° to 140°F Humidity 85% or less</p> <p>Manual Trolleys</p> <p>Capacity Range Push – 1/4 – 6 Ton Geared – 3 – 6 Ton</p> <p>Control Option on Hoist TCLP and TCLG – Pendant and cord</p> <p>Standard Hand Chain Length On geared trolleys Hangs approximately 2' less than fully extended bottom hook (longer lengths available)</p>
---	--



TCLM1000P2



TCLP500P

TCL Lube Free Air Powered Hoists with Air Powered, Push and Geared Trolleys

PENDANT MODEL WITH AIR POWERED TROLLEY—SPECIFICATIONS

Cap. (Tons)	Product Code	Standard Lift (ft)	Push Button Hose L (ft)	Up/Down Speeds (ft/min @ 90 psi)		Traversing Speed (ft/min)	Air Consumption Rates (cfm @ 90 psi)			Flange Width Adjustability B (in)	Minimum Allow. Radius for Curve (in)	Load Chain Diameter (mm) x Chain Fall Lines	Net Weight (lbs)	Weight for Additional One Foot of Lift (lbs)			
							TCR		MCL								
				No Load	Full Load		No Load	Full Load									
1/4	TCLM250P	10	8.2	151 / 105	85 / 144	65	64 / 57	57 / 64	53	2.28 to 5.00	137.8	6.3 x 1	151	0.6			
1/2	TCLM500P			79 / 53	43 / 79		64 / 57	57 / 64	53						6.3 x 1	151	0.6
1	TCLM1000P2			39 / 26	21 / 39		64 / 57	57 / 64	53						6.3 x 2	165	1.2
3	TCLM3000P	10	8.6	24 / 14	10 / 22	65	131 / 124	106 / 141	53	3.94 to 6.02	51.2	12.5 x 1	326	2.3			
6	TCLM6000P2			12 / 7.2	4.9 / 11		131 / 124	106 / 141	53	4.92 to 7.02	78.7	12.5 x 2	461	4.6			

PENDANT MODEL WITH AIR POWERED TROLLEY—DIMENSIONS

Cap. (Tons)	Product Code	Headroom C (in)	b (in)	b' (in)	d (in)	e (in)	e' (in)	g (in)	i (in)	j (in)	k (in)	m (in)	n (in)	r (in)	t (in)
1/4	TCLM250P	18.3	12.4	15.6	9.9	6.2	3.7	1.0	3.7	0.9	4.8	4.6	4.4	2.0	1.2
1/2	TCLM500P	18.3	12.4	15.6	9.9	6.2	3.7	1.0	3.7	0.9	4.8	4.6	4.4	2.0	1.2
1	TCLM1000P2	19.3	12.4	15.6	9.9	6.2	3.7	1.1	3.7	0.9	4.8	4.6	4.4	2.0	1.2
3	TCLM3000P	29.5	13.4	17.4	10.5	6.9	3.9	1.3	4.9	1.4	5.0	5.1	5.5	2.8	1.7
6	TCLM6000P2	34.1	15.7	19.8	10.8	8.1	4.3	1.7	5.5	1.4	5.5	5.7	6.1	3.9	2.3

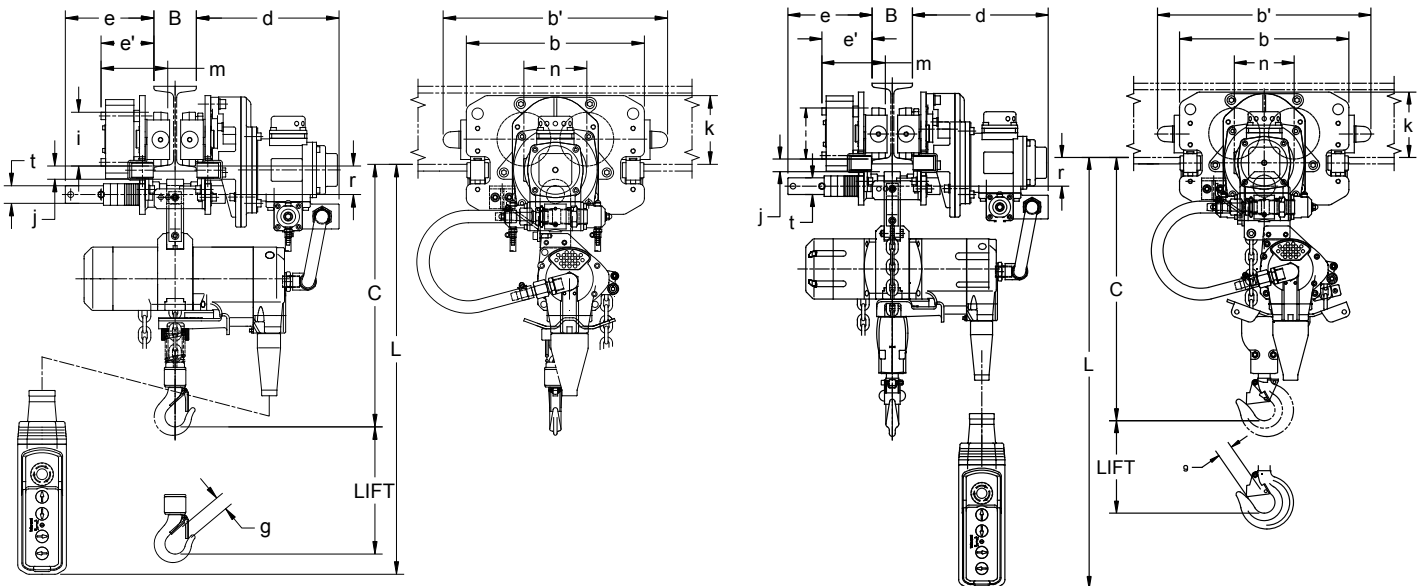

TCLM500P

TCLM1000P2

PENDANT MODEL WITH PUSH OR GEARED TROLLEY—SPECIFICATIONS

Cap. (Tons)	Product Code	Standard Lift (ft)	Push Button Hose L (ft)	Up/Down Speeds (ft/min @ 90 psi)		Up/Down Air Consumption Rates (cubic ft/min @ 90 psi)		Flange Width Adjustability B (in)		Minimum* Allow. Radius for Curve (in)	Load Chain Diameter (mm) x Chain Fall Lines	Net Weight (lbs)	Weight for Additional One Foot of Lift (lbs)
				No Load	Full Load	No Load	Full Load	Standard	Optional				
1/4	TCLPL250P	10	8.2	151 / 105	85 / 144	64 / 57	57 / 64	2.28 to 4.00	4.01 to 8.00	13.8	6.3 x 1	56	0.6
1/2	TCLPL500P			79 / 53	43 / 79	64 / 57	57 / 64		OR 8.01 to 12.00		6.3 x 1	56	0.6
1	TCLPL1000P2			39 / 26	21 / 39	64 / 57	57 / 64	2.28 to 5.00	5.01 to 8.00 OR 8.01 to 12.00	17.7	6.3 x 2	78	1.2
3	TCLP(TCLG)3000P	10	8.6	24 / 14	10 / 22	131 / 124	106 / 141	3.23 to 6.02	6.03 to 12.00	25.6 (66.9)	12.5 x 1	271 (287)	2.3 (2.9)
6	TCLP(TCLG)6000P2			12 / 7.2	4.9 / 11	131 / 124	106 / 141	5.50 to 8.66	8.67 to 12.00	118.1	12.5 x 2	507 (553)	4.6 (5.26)

Figures in parenthesis are data for geared trolley
 *Minimum flange width for curved beam: 1 Ton Push and 1/8 to 1Ton Geared = 2.87 in.
 3 Ton Push and Geared = 3.50 in.

CORD MODEL WITH PUSH OR GEARED TROLLEY—SPECIFICATIONS

Cap. (Tons)	Product Code	Standard Lift (ft)	Cord L (ft)	Up/Down Speeds (ft/min @ 90 psi)		Up/Down Air Consumption Rates (cubic ft/min @ 90 psi)		Flange Width Adjustability B (in)		Minimum* Allow. Radius for Curve (in)	Load Chain Diameter (mm) x Chain Fall Lines	Net Weight (lbs)	Weight for Additional One Foot of Lift (lbs)
				No Load	Full Load	No Load	Full Load	Standard	Optional				
1/4	TCLPL250C	10	7.3	151 / 105	85 / 144	64 / 57	57 / 64	2.28 to 4.00	4.01 to 8.00	13.8	6.3 x 1	54	0.6
1/2	TCLPL500C			79 / 53	43 / 79	64 / 57	57 / 64		OR 8.01 to 12.00		6.3 x 1	54	0.6
1	TCLPL1000C2			39 / 26	21 / 39	64 / 57	57 / 64	2.28 to 5.00	5.01 to 8.00 OR 8.01 to 12.00	17.7	6.3 x 2	76	1.2
3	TCLP(TCLG)3000C	10	7.3	24 / 14	10 / 22	131 / 124	106 / 141	3.23 to 6.02	6.03 to 12.00	25.6 (66.9)	12.5 x 1	269 (284)	2.3 (2.9)
6	TCLP(TCLG)6000C2			12 / 7.2	4.9 / 11	131 / 124	106 / 141	5.50 to 8.66	8.67 to 12.00	118.1	12.5 x 2	505 (551)	4.6 (5.2)

Figures in parenthesis are data for geared trolley
 *Minimum flange width for curved beam: 1 Ton Push and 1/8 to 1Ton Geared = 2.87 in.
 3 Ton Push and Geared = 3.50 in.

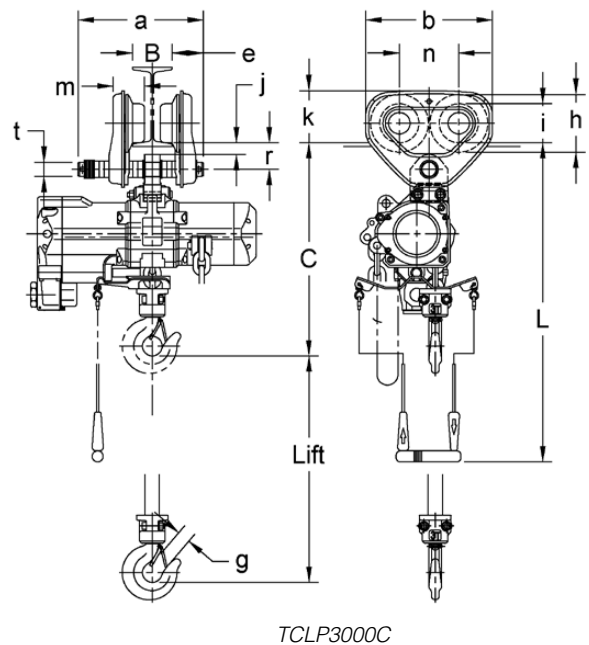
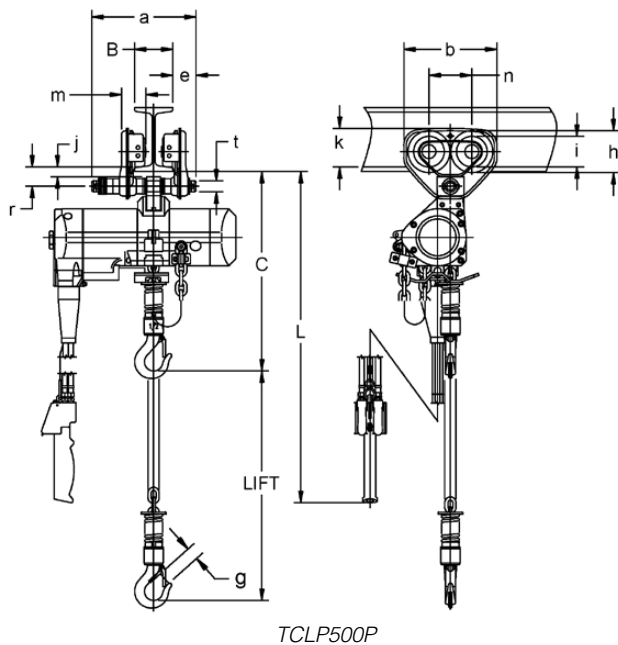

TCL Lube Free Air Powered Hoists with Air Powered, Push and Geared Trolleys

PENDANT AND CORD MODEL WITH PUSH TROLLEY—DIMENSIONS

Cap. (Tons)	Product Code	Headroom C (in)	a (in)	b (in)	e (in)	g (in)	h (in)	i (in)	j (in)	k (in)	m (in)	n (in)	r (in)	t (in)
1/4	TCLP250P	15.4	8.0	7.2	1.8	1.0	3.2	2.36	0.8	3.0	1.9	3.3	1.5	0.87
1/2	TCLP500P	15.4	8.0	7.2	1.8	1.0	3.2	2.36	0.8	3.0	1.9	3.3	1.5	0.87
1	TCLP1000P2	17.0	9.8	9.3	2.2	1.1	4.2	2.80	1.2	3.7	2.2	4.4	2.0	0.98
3	TCLP3000C/P	21.1	12.6	12.8	3.2	1.3	5.8	3.94	1.2	5.3	3.1	6.0	2.7	1.42
6	TCLP6000C2/P2	28.8	17.6	18.9	4.1	1.7	7.3	6.10	3.5	6.7	3.4	7.7	6.0	2.76

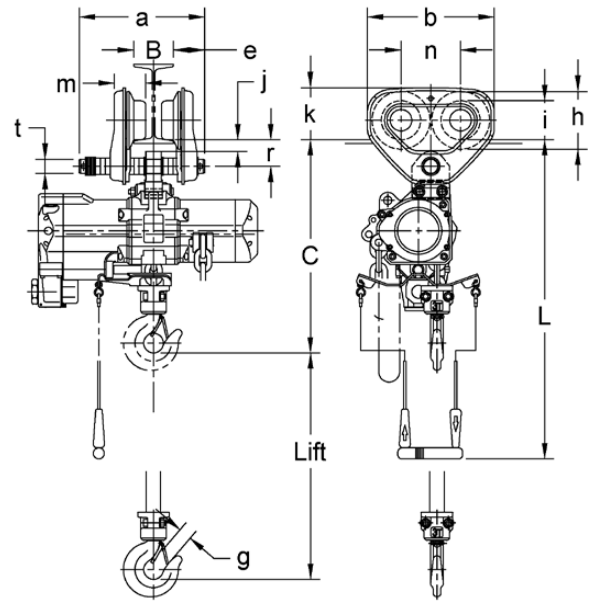
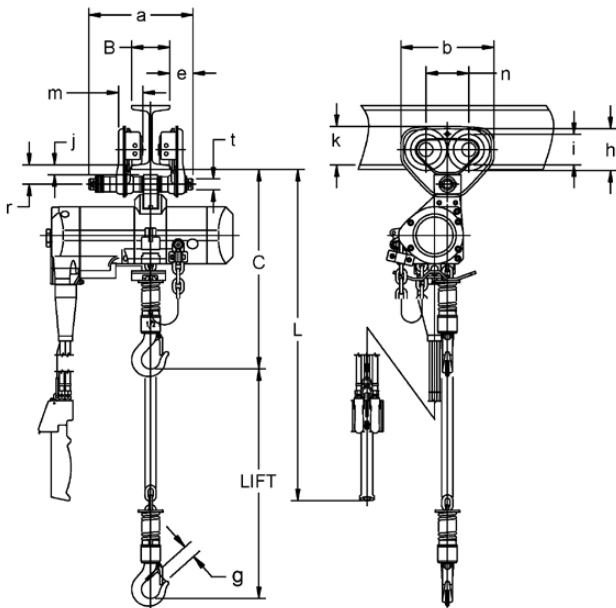

PENDANT AND CORD MODEL WITH GEARED TROLLEY—DIMENSIONS

Cap. (Tons)	Product Code	Headroom C (in)	E (ft)	a (in)	b (in)	e (in)	g (in)	h (in)	i (in)	j (in)	k (in)	k' (in)	m (in)	n (in)	r (in)	t (in)	u (in)
3	TCLG3000C/P	21.5	9.8	31.2	12.8	15.9	1.3	5.8	3.94	1.2	5.3	4.5	3.1	6.0	2.7	1.42	7.2
6	TCLG6000C2/P2	33.4	10.8	29.7	18.9	14.6	1.7	7.3	6.10	3.4	6.7	6.5	3.4	7.7	6.0	2.76	8.4

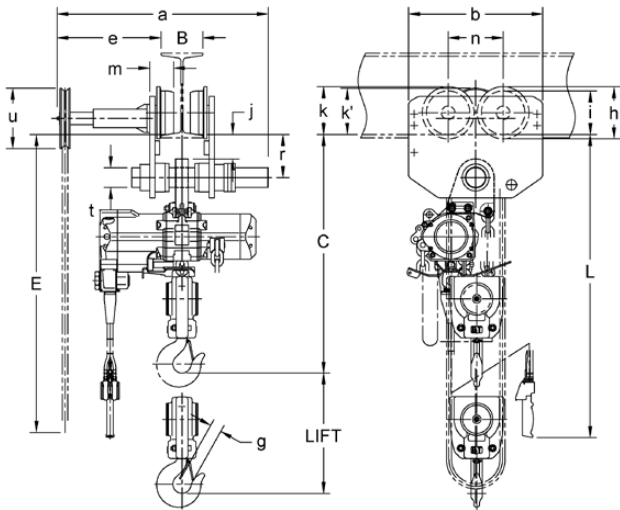

TCLG6000P2

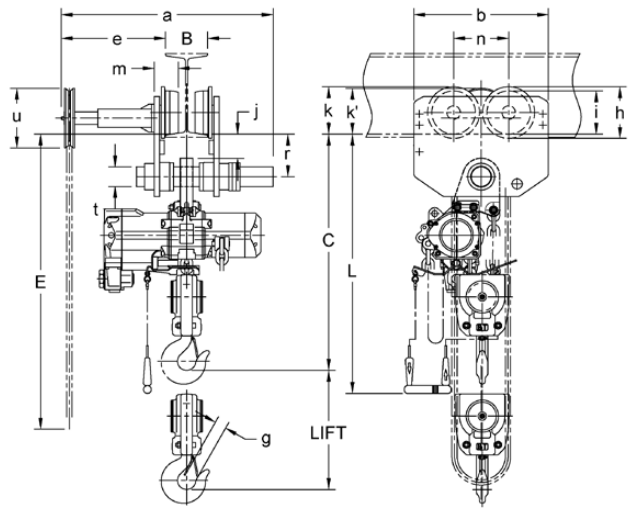

TCLG6000C2

AH Mini-Cat Air Powered Hoists with Pendant and Cord Controls and Hook Suspension

The AH Mini-Cat Series of air hoists was designed with exceptionally low headroom and will easily handle many construction, assembly line and workstation applications.

Features and Benefits

<p>Unlimited Duty Cycle For continuous operation</p> <p>Extremely Compact & Lightweight Body Allows for easy operation, transportation and storage</p> <p>Airtight Hoist Results in efficient use of air</p> <p>High Speed Lifting Maximum speed gets jobs done quickly</p> <p>Vane Motor Design Permits very fine feathering control</p> <p>Aluminum Valve Section Reduces effects of corrosion</p> <p>Low Noise Levels Adds to operator comfort</p> <p>Disc Motor Brake System For reliable load support</p> <p>Nickel Plated Load Chain Resistant to corrosion, abrasion and wear</p>	<p>Capacity Range 250 – 500 lb.</p> <p>Standard Lift 10' (longer lifts available)</p> <p>Standard Pendant or Cord Length Hangs approximately 4' above the hoist's fully extended bottom hook (longer lengths available)</p> <p>Air Supply Requirement 19 – 34 cfm at 60 – 90 psi</p> <p>Air Lubrication Requirement Minimum 10 to 15 drops of oil per minute (0.2 – 0.3 cc/min.)</p> <p>Air Filtration Maximum 5 micron air filter or finer required</p> <p>Air Inlet Port 3/8" NPT</p> <p>Air Supply Hose Minimum Size 3/8"</p> <p>Operating Conditions Temperature range +14° to 140°F Humidity 85% or less</p> <p>Chain Containers Optional Plastic</p>
---	--

Standard Hoist Specifications

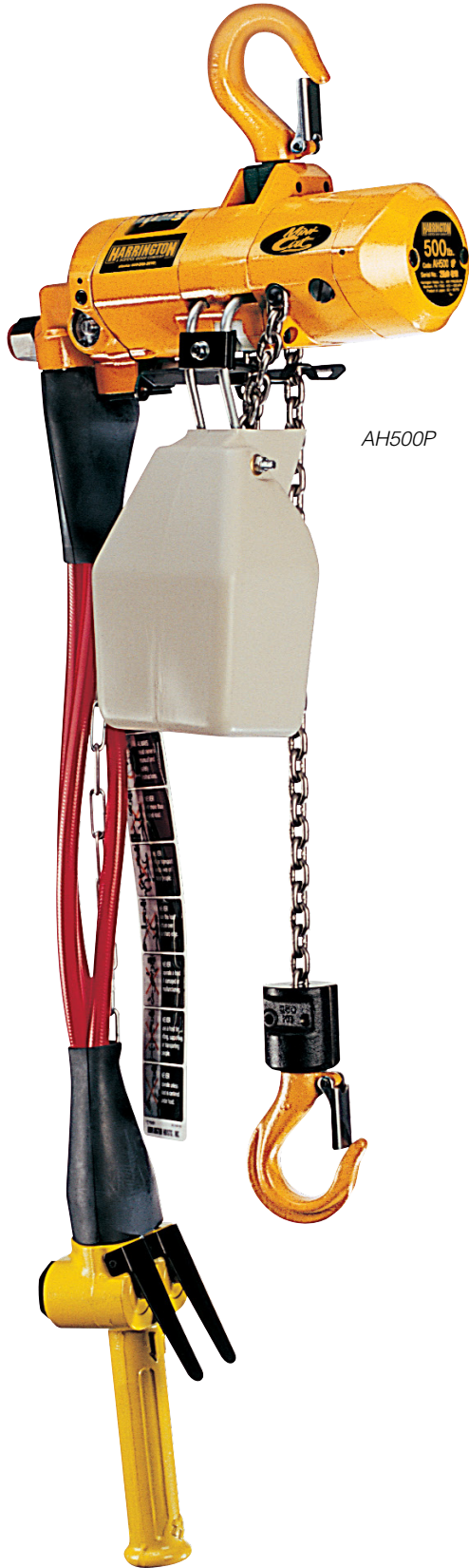

AH500P



AH500C

AH Mini-Cat Air Powered Hoists with Pendant and Cord Controls and Hook Suspension

PENDANT MODEL—SPECIFICATIONS

Capacity (lbs)	Product Code	Headroom (in)	Standard Lift (ft)	Load Chain Dia. (mm) x Chain Fall Lines	Net Weight with Standard Lift (lbs)	Weight for Additional One Foot of Lift (lbs)
250	AH250P	12.0	10	4 x 1	19	0.49
500	AH500P	12.0	10	4 x 1	19	0.49

Speeds—ft/min at 90 psi:

Capacity (lbs)	Product Code	Up		Down	
		Full Load	No Load	Full Load	No Load
250	AH250P	42 (33)	55 (48)	48 (45)	43 (38)
500	AH500P	29 (18)	55 (48)	53 (51)	43 (38)

Air Consumption—cfm at 90 psi:

Capacity (lbs)	Product Code	Up		Down	
		Full Load	No Load	Full Load	No Load
250	AH250P	28 (21)	31 (24)	27 (21)	26 (20)
500	AH500P	26 (19)	31 (24)	28 (22)	26 (20)

Values in parentheses for air supply at 60 psi.

PENDANT MODEL—DIMENSIONS

Measurements in inches

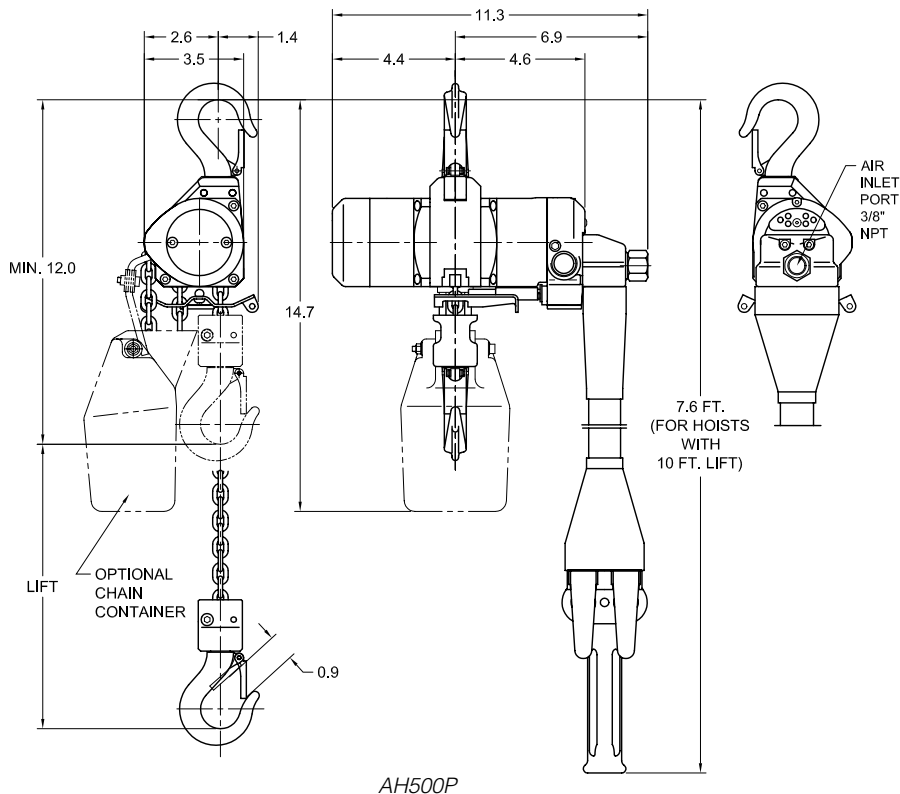

CORD MODEL—SPECIFICATIONS

Capacity (lbs)	Product Code	Headroom (in)	Standard Lift (ft)	Load Chain Dia. (mm) x Chain Fall Lines	Net Weight with Standard Lift (lbs)	Weight for Additional One Foot of Lift (lbs)
250	AH250C	12.0	10	4 x 1	15	0.26
500	AH500C	12.0	10	4 x 1	15	0.26

Speeds—ft/min at 90 psi:

Capacity (lbs)	Product Code	Up		Down	
		Full Load	No Load	Full Load	No Load
250	AH250C	47 (37)	61 (53)	51 (47)	45 (40)
500	AH500C	32 (20)	61 (53)	56 (54)	45 (40)

Air Consumption—cfm at 90 psi:

Capacity (lbs)	Product Code	Up		Down	
		Full Load	No Load	Full Load	No Load
250	AH250C	32 (24)	34 (27)	30 (24)	28 (23)
500	AH500C	29 (21)	34 (27)	32 (26)	28 (23)

Values in parentheses for air supply at 60 psi.

CORD MODEL—DIMENSIONS

Measurements in inches

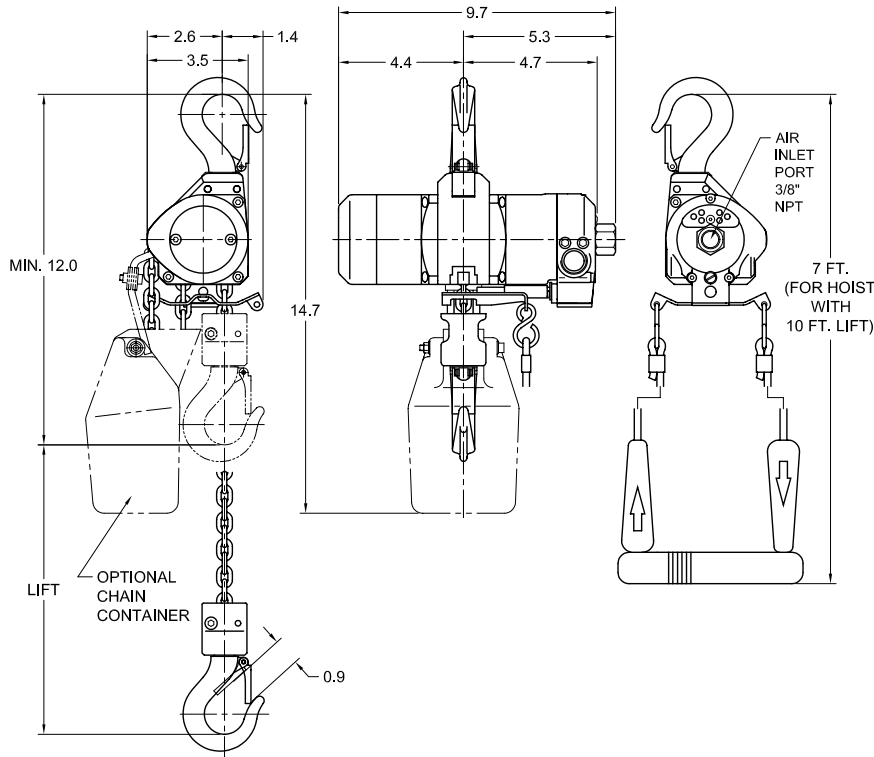

AH500C

AH Mini-Cat Air Powered Hoists with Manipulator Control and Hook Suspension

Harrington's AH Mini-Cat Series air hoists also offer a unique ergonomic manipulator control feature designed to support the special repetitive working practices of assembly line and workstation areas in a wide variety of industries.

Refer to page 38 for standard hoist specifications.

Unique Features and Benefits

Manipulator Control

Unique one-handed control replaces standard pendant or cord.

This design is adjustable for either left- or right-handed operation.

Permits the operator to have a free hand to easily position the load.

Unique Hoist Specifications

Standard Lengths

6.5' Lift — 9' reach (approx.)

13' lift — 17' reach (approx.)
(reach equals lift plus headroom)

Chain Containers

Standard
Plastic



MANIPULATOR MODEL—SPECIFICATIONS

Capacity (lbs)	Product Code	Headroom (in)	Standard Lift (ft)	Load Chain Dia. (mm) x Chain Fall Lines	Net Weight with Standard Lift (lbs)	Weight for Additional One Foot of Lift (lbs)
250	AH250M	33.0	6.5	4 x 1	24	0.47
500	AH500M	33.0	6.5	4 x 1	24	0.47

Speeds—ft/min at 90 psi:

Capacity (lbs)	Product Code	Up		Down	
		Full Load	No Load	Full Load	No Load
250	AH250M	41 (32)	54 (47)	47 (44)	42 (37)
500	AH500M	29 (18)	54 (47)	53 (50)	42 (37)

Air Consumption—cfm at 90 psi:

Capacity (lbs)	Product Code	Up		Down	
		Full Load	No Load	Full Load	No Load
250	AH250M	28 (21)	31 (24)	27 (21)	26 (20)
500	AH500M	26 (19)	31 (24)	28 (22)	26 (20)

Values in parentheses for air supply at 60 psi.

MANIPULATOR MODEL—DIMENSIONS

Measurements in inches

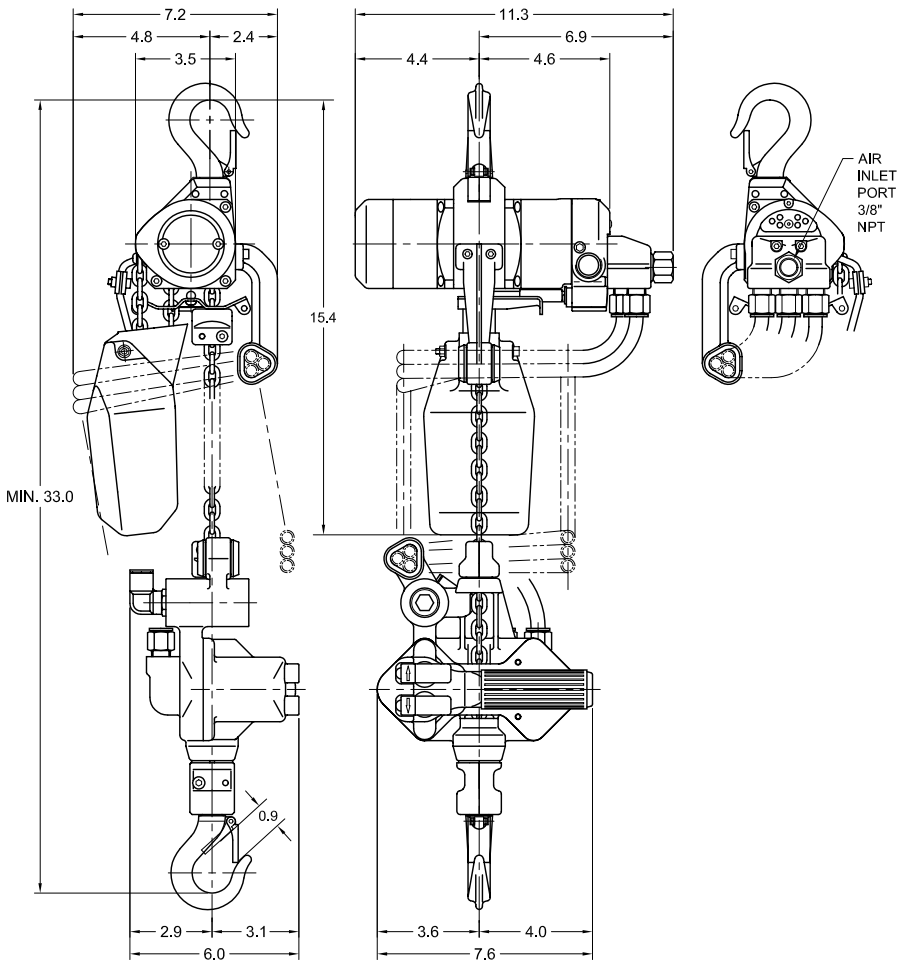

AH500M

AH Mini-Cat Air Powered Hoists with Lug Suspension

MINI TROLLEY—SPECIFICATIONS

Maximum Capacity (lbs)	Product Code	Adjustable Beam Width B (in)	Minimum* Radius for Curve (in)	Net Weight (lbs)	Approximate Shipping Weight (lbs)
525	ET525	1.97 – 3.94	23.6	4.0	5.0

Lug mount only.

*For larger flanges, hook mount AH air hoists to PTF2/GTF2 1/2 or 1 Ton trolleys.



ET525

MINI TROLLEY—DIMENSIONS

Measurements in inches

Dimensions for pendant and cord controls are identical.

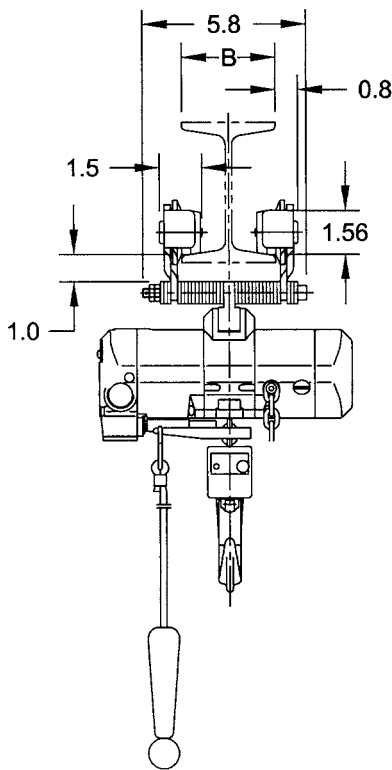

AH500C

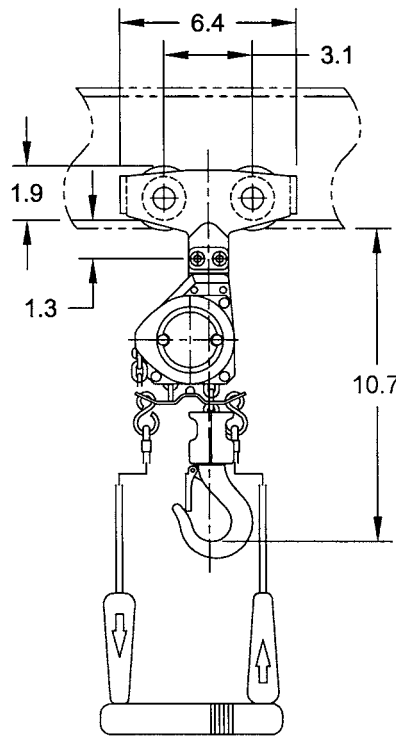

AH500C

AH Mini-Cat Air Powered Hoists with Options

HOISTS WITH PLASTIC CHAIN CONTAINERS—DIMENSIONS

Hoist Product Code	Max. Lift (ft)	Container Headroom D (in)	Hoist Headroom C (in)
AH250C/P	10	14.7	12.0
AH500C/P	20	16.1	

Chain containers are easily installed.

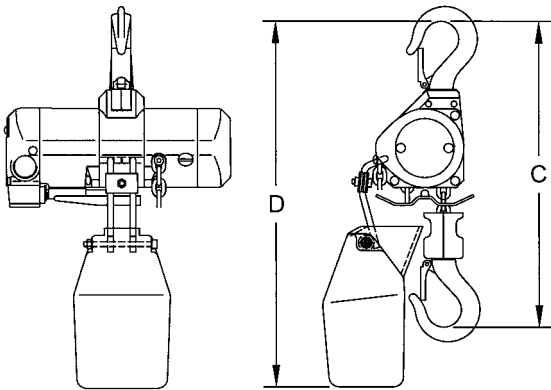

AH with Chain Container

HOISTS WITH L, FL AND FRL—DIMENSIONS

Cap. (lbs)	Product Code	a (in)		b (in)	d (in)	e (in)	g (in)	h (in)		k (in)
		C	P & M					L & FL	FRL	
250	AH250C/P/M	6.6	8.2	4.7	4.4	2.6	5.3	4.2	5.5	11.7
500	AH500C/P/M	6.6	8.2	4.7	4.4	2.6	5.3	4.2	5.5	11.7

L = Lubricator

FL = Filter and Lubricator

FRL = Filter, Regulator and Lubricator

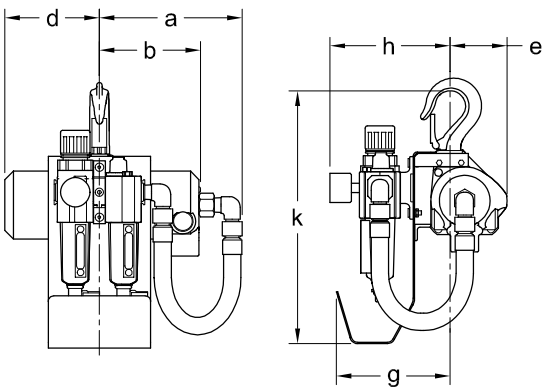

AH with L, FL and FRL

Technical Data

TCR TOP AND BOTTOM HOOK—DIMENSIONS

Product Code	a (in)	b (in)	c (in)	d (in)	e (in)	f (in)	g (in)	h (in)
TCR250C/P	1.4	0.9	1.1	0.9	1.6	1.6	1.1	4.2
TCR500C/P	1.4	0.9	1.1	0.9	1.6	1.6	1.1	4.2
TCR1000C2/P2	1.4	0.9	1.1	0.9	1.6	1.6	1.1	4.2
TCR1000C/P	1.4	0.9	1.1	0.9	1.6	1.6	1.1	4.2
TCR2000C2/P2	1.8	1.2	1.5	1.2	1.8	2.0	1.1	4.9
TCR10000C2/P2	2.8	2.4	2.4	2.2	2.4	2.6	1.6	7.1
TCR25000C2/P2	4.9	3.5	3.9	3.5	4.9	4.9	3.1	13.1

TCK TOP AND BOTTOM HOOK—DIMENSIONS

Product Code	a (in)	b (in)	c (in)	d (in)	e (in)	f (in)	g (in)	h (in)
TCK3000C/P	2.1	1.5	1.8	1.3	2.0	2.4	1.3	5.9
TCK6000C2/P2	2.3	1.6	1.9	1.6	2.6	2.8	1.7	6.8

TCS TOP AND BOTTOM HOOK—DIMENSIONS

Product Code	a (in)	b (in)	c (in)	d (in)	e (in)	f (in)	g (in)	h (in)
TCS250C/P	0.6	0.8	0.6	0.8	1.4	1.3	1.0	2.9
TCS500C/P	0.6	0.8	0.6	0.8	1.4	1.3	1.0	2.9
TCS1000C2/P2	1.4	0.9	1.1	0.9	1.6	1.6	1.1	4.2

TCL TOP AND BOTTOM HOOK—DIMENSIONS

Product Code	a (in)	b (in)	c (in)	d (in)	e (in)	f (in)	g (in)	h (in)
TCL250C/P	0.6	0.8	0.6	0.8	1.4	1.3	1.0	2.9
TCL500C/P	0.6	0.8	0.6	0.8	1.4	1.3	1.0	2.9
TCL1000C2/P2	1.4	0.9	1.1	0.9	1.6	1.6	1.1	4.2
TCL3000C/P	2.1	1.5	1.8	1.3	2.0	2.4	1.3	5.9
TCL6000C2/P2	2.3	1.6	1.9	1.6	2.6	2.8	1.7	6.8

AH TOP AND BOTTOM HOOK—DIMENSIONS

Product Code	a (in)	b (in)	c (in)	d (in)	e (in)	f (in)	g (in)	h (in)
AH250C/P/M	0.7	0.8	0.6	0.8	1.4	1.3	0.9	2.9
AH500C/P/M	0.7	0.8	0.6	0.8	1.4	1.3	0.9	2.9

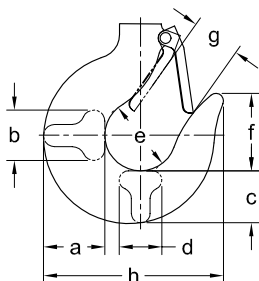

TCR CHAIN—DIMENSIONS

Product Code	a (in)	b (in)	d (in)	p (in)
TCR250C/P	0.31	0.87	0.25	0.75
TCR500C/P				
TCR1000C2/P2				
TCR1000C/P	0.35	0.98	0.28	0.83
TCR2000C2/P2				
TCR10000C2/P2	0.88	2.14	0.63	1.77
TCR25000C2/P2	1.22	2.95	0.87	2.60

TCK CHAIN—DIMENSIONS

Product Code	a (in)	b (in)	d (in)	p (in)
TCK3000C/P	0.62	1.73	0.49	1.50
TCK3000C2/P2				

TCS CHAIN—DIMENSIONS

Product Code	a (in)	b (in)	d (in)	p (in)
TCS250C/P	0.31	0.87	0.25	0.75
TCS500C/P				
TCS1000C2/P2				

TCL CHAIN—DIMENSIONS

Product Code	a (in)	b (in)	d (in)	p (in)
TCL250C/P	0.31	0.87	0.25	0.75
TCL500C/P				
TCL1000C2/P2				
TCL3000C/P	0.62	1.73	0.49	1.50
TCL6000C2/P2				

AH CHAIN—DIMENSIONS

Product Code	a (in)	b (in)	d (in)	p (in)
AH250C/P/M	0.20	0.53	0.16	0.48
AH500C/P/M				

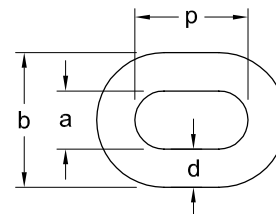

Technical Data

TYPICAL ARRANGEMENTS OF FRL AND AIR SUPPLY HOSE LENGTHS

The connection from the air supply system piping to the hoist must be made with a flexible pressure hose. Due to normal losses in air supply lines:

- Do not use hose smaller than specified.
- Limit the length of the hose to that specified below.

If your application exceeds these requirements, consult Customer Service.

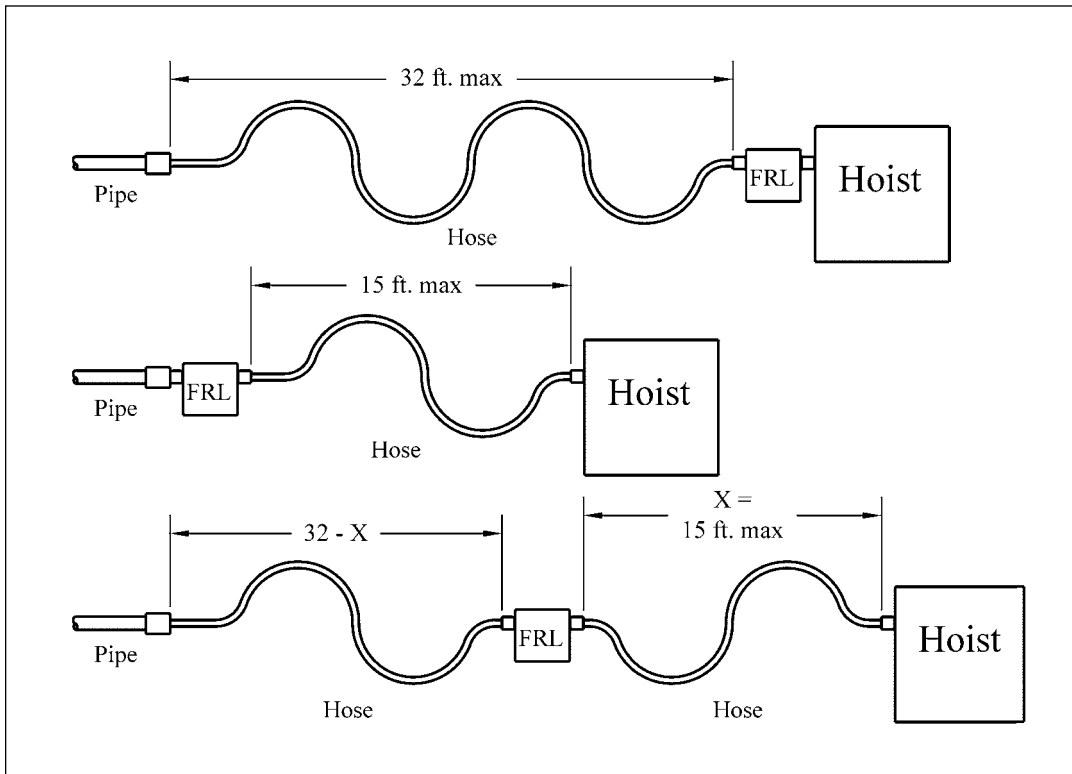

FRL = Filter, Regulator and Lubricator

BULLARD® AND SHUR-LOC® HOOKS

These hooks offer a positive locking latch feature. Consult Customer Service for full details.



Bullard®

Shur-Loc®

Product Code

TCR SERIES

TCR 1000 P 2

Type:
TCR = TCR Hook Mount
TCRM = TCR with Motorized Trolley
TCRP = TCR with Push Trolley
TCRG = TCR with Geared Trolley

Capacity Code:
250 = 1/4 Ton
500 = 1/2 Ton
1000 = 1 Ton
2000 = 2 Ton
10000 = 10 Ton
25000 = 25 Ton

Pendant/Cord:
P = Pendant
C = Cord

No. Falls:
2 = 2 Falls

TCK SERIES

TCK 6000 P 2

Type:
TCK = TCK Hook Mount
TCKM = TCK with Motorized Trolley
TCKP = TCK with Push Trolley
TCKG = TCK with Geared Trolley

Capacity Code:
3000 = 3 Ton
6000 = 6 Ton

Pendant/Cord:
P = Pendant
C = Cord

No. Falls:
2 = 2 Falls

TCS CHEETAH SERIES

TCS 1000 P 2

Type:
TCS = TCS Hook Mount
TCSP = TCS with Push Trolley

Capacity Code:
250 = 1/4 Ton
500 = 1/2 Ton
1000 = 1 Ton

Pendant/Cord:
P = Pendant
C = Cord

No. Falls:
2 = 2 Falls

TCL LUBE FREE SERIES

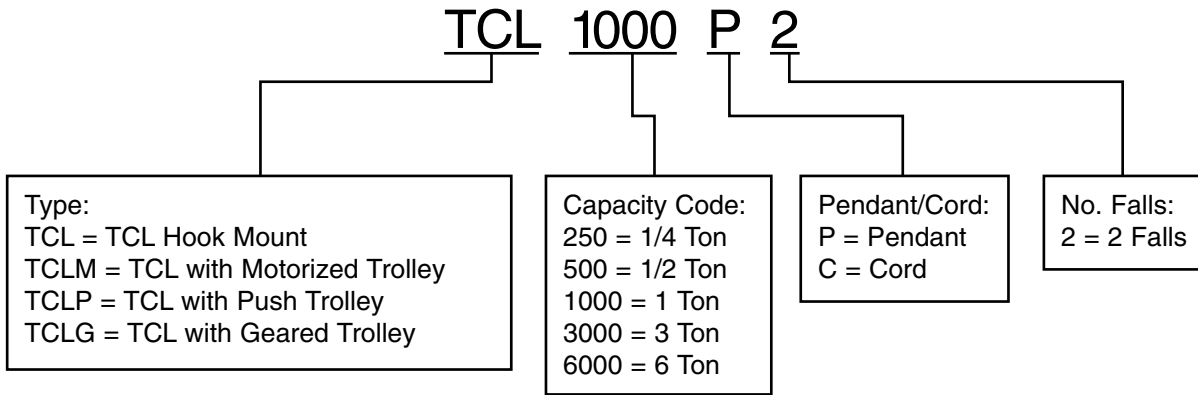

AH MINI-CAT SERIES

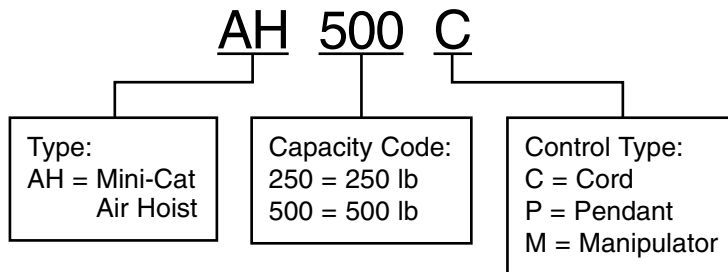

Notes

Complete Product Offering

Over the years Harrington has continued to respond to the needs of our customers by further expanding our product offerings. In addition to the many models described in this catalog, our full series of product catalogs, as shown below, will provide you with all of the information you will need to answer questions, specify a product and place an order. For catalog copies or answers to specific product questions, please contact our Customer Service Department by calling 800-233-3010 or e-mail customerservice@harringtonhoists.com

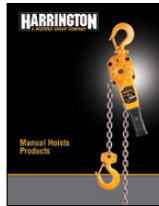

Manual Hoist Products Catalog

Refer to this Harrington catalog for detailed information on the following:

- Lever hoists
- Hand chain hoists
- Hoist and trolley combinations
- Low headroom trolley hoists
- Push and geared trolleys
- Hoist load testers

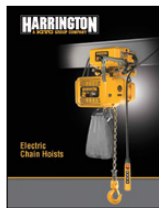

Electric Powered Hoists Catalog

Refer to this Harrington catalog for detailed information on the following:

- Three phase electric hoists and trolleys
- Single phase electric hoists and trolleys
- Ergonomic electric hoists



Electric Wire Rope Hoists Catalog

Refer to this Harrington catalog for detailed information on the following:

- Ultra-low headroom trolley hoists



Crane Components Catalog

Refer to this Harrington catalog for detailed information on the following:

- End trucks-top running-motorized, geared and push
- End trucks-underhung-motorized, geared and push
- Double girder MAX-E-Lift end trucks
- Convertible push end trucks
- Beam accessory kits

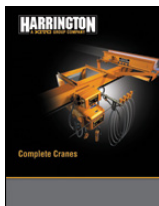

Complete Cranes Catalog

Refer to this Harrington catalog for detailed information on the following:

- Heavy-duty Class C single girder top running and underhung cranes
- Heavy-duty Class C double girder top running and underhung cranes
- Medium-duty top running and underhung push cranes
- Crane control panels

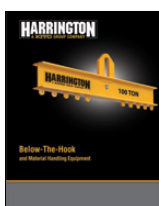

Below-The-Hook and Material Handling Equipment

Refer to this Harrington catalog for detailed information on the following:

- Lifting beams and spreader beams
- Roll lifters, coil lifters and tongs
- Sheet lifters and pallet lifters
- Fork truck accessories
- Material stands and material baskets

**CONTACT YOUR NEARBY
HARRINGTON DISTRIBUTOR**

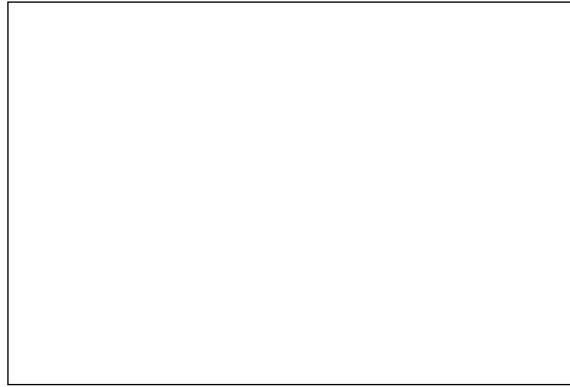

Warranty

All products sold by Harrington Hoists, Inc. are warranted to be free from defects in material and workmanship from date of shipment by Harrington for the following periods:

1 year—Electric and Air Powered Hoists (excluding (N)ER2 Enhanced Features Models, EQ/SEQ Hoists), Powered Trolleys, Powered Tiger Track Jibs and Gantries, Crane Components, Spare/Replacement Parts, Below-The-Hook and Material Handling Equipment

2 years—Manual Hoists & Trolleys, Beam Clamps

3 years—(N)ER2 Enhanced Features Model Hoists, EQ/SEQ Hoists, RY Wire Rope Trolley Hoists

5 years—Manual Tiger Track Jibs and Gantries, TNER, and EQ/SEQ Pull-Rotor Brakes and RY Motor Brakes

10 years—(N)ER2 “The Guardian” Smart Brake

The product must be used in accordance with manufacturer’s recommendations and must not have been subject to abuse, lack of maintenance, misuse, negligence, or unauthorized repairs or alterations.

Should any defect in material or workmanship occur during the above time period in any product, as determined by Harrington Hoist’s inspection of the product, Harrington Hoists, Inc. agrees, at its discretion, either to replace (not including installation) or repair the part or product free of charge and deliver said item F.O.B. Harrington Hoists, Inc. place of business to customer.

Customer must obtain a Return Goods Authorization as directed by Harrington or Harrington’s published repair center prior to shipping product for warranty evaluation. An explanation of the complaint must accompany the product. Product must be returned freight prepaid. Upon repair, the product will be covered for the remainder of the original warranty period. Replacement parts installed after the original warranty period will only be eligible for replacement (not including installation) for a period of one year from the installation date. If it is determined there is no defect, or that the defect resulted from causes not within the scope of Harrington’s warranty, the customer will be responsible for the costs of returning the product.

Harrington Hoists, Inc. disclaims any and all other warranties of any kind expressed or implied as to the product’s merchantability or fitness for a particular application. Harrington will not be liable for death, injuries to persons or property or for incidental, contingent, special or consequential damages, loss or expense arising in connection with the use or inability whatever, regardless of whether damage, loss or expense results from any act or failure to act by Harrington, whether negligent or willful, or from any other reason.



4710 N Brady St
Davenport, IA 52803
1-8700-397-6690
Sales@barroneq.com
www.barroneq.com

