

ROLL UP DOOR SHOWN OPEN

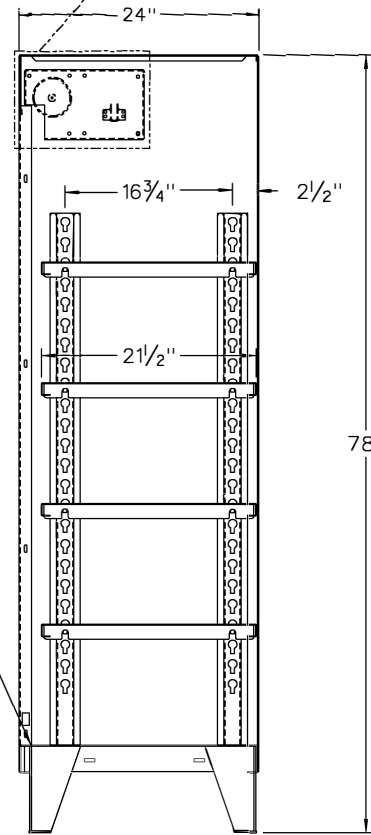
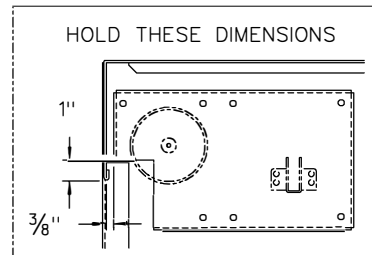

SECTION "A-A"

S.O.: _____
 QTY.: _____
 FINISH: _____

REV.	DATE	DESCRIPTION	BY	CK
03	01/29/19	REV BODY/BOT FOR DOUBLE WALL DOOR	JH	DL
02	03/23/18	ITEM *4 WAS L/R	DF	
01	06/22/17	REDUCED DOOR WIDTH 1/8"	DF	

THIS DOCUMENT CONTAINS PROPRIETARY INFORMATION. DUPLICATION OR DISCLOSURE IS PROHIBITED WITHOUT THE EXPRESSED WRITTEN CONSENT OF FABRICATED METALS CORP.

TOLERANCES: UNLESS OTHERWISE SPECIFIED
 PLATE/PIPE +/- 1/16"
 MACHINING +/- .005"
 ANGLES +/- 1 DEG.



DESCRIPTION: 46-RUDD-244

DRAWN BY: D.FARMER
 APPROVED: JH
 SCALE: NTS
 ECN: 01/29/19
 DATE: 12/05/14

PART NO.
 DWG. NO. RU-15527-03
 SHEET OF