

Door Folding Gates

Finished Assembly

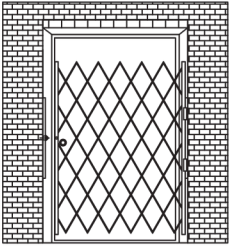

Tools Needed

3/4" Masonry DrillBit 

1/4" Masonry or Wood Drill Bit 

Parts Needed

5/16" x 2" Long Lag Bolt

Masonry Door Frame or Wall Installations
(wall installation may require lead anchor)

INSTALLATION INSTRUCTIONS

- 1) Stand door gate against door frame where you intend to mount it. Mark the mounting surface through the holes in the hinge bar with a pencil. Drill mounting holes into the mounting surface. For mounting into wood use 5/16" x 2" lag bolts. For steel, drill and tap for 5/16" x 1" bolts. Brick or concrete mountings uses 5/16" x 2" lag bolts in 3/8" holes with lead anchors. (See Figure 1)

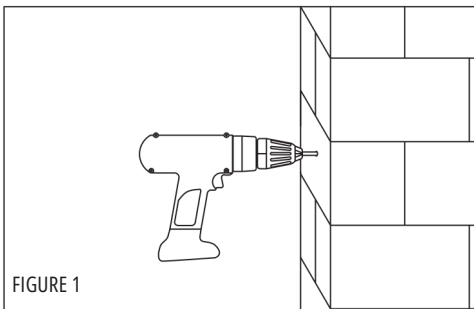

- 3) Stretch door gate across opening. Place locking bar onto mounting surface, align padlock holes and mark mounting surface through the holes in the locking bar with a pencil. Drill mounting holes and secure with bolts.

- 4) Stretch door gate across opening into locking bar, and insert padlock. (See Figure 3)

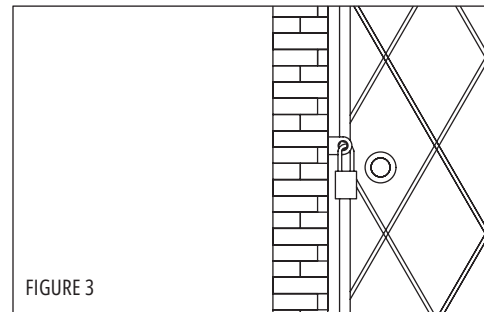

- 2) Mount the door gate by inserting bolts through hinge bar set into mounting surface. (See Figure 2)

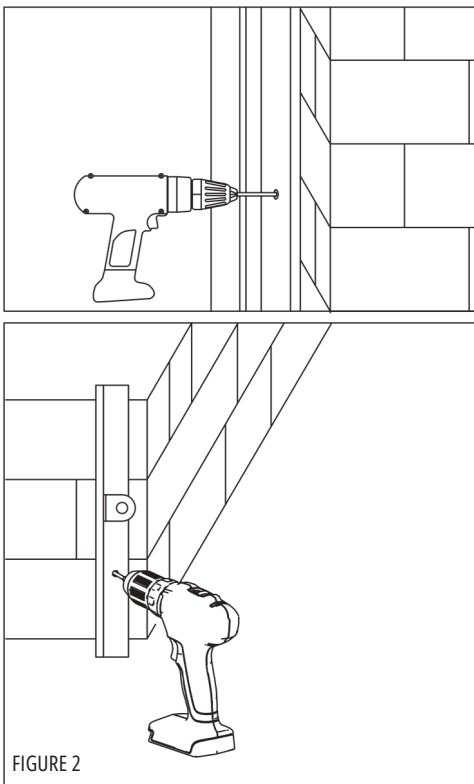

NOTE: Door gates can be installed in the casing of the door or outside the door. Gate can be mounted on the left or right. Simply turn the gate upside down to mount on the opposite side.

Retainer straps hold door gates in retracted position

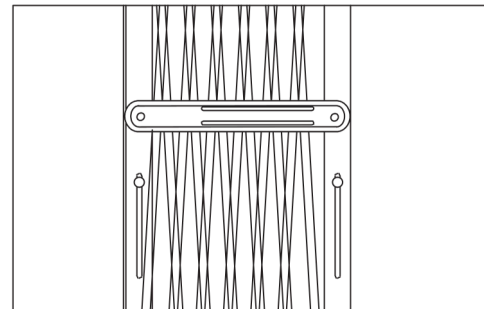

4710 N Brady Street • DAVENPORT, IA 52806

• Barron Equipment • 800-397-6690 • 563-391-1321 FAX

Email SALES@BARRONEQ.COM