

Portable Barrier Folding Gates

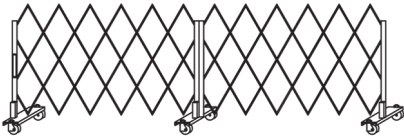

Finished Assembly



Tools Needed

Flathead Screwdriver



3/4" (19mm) Wrench or Socket



Parts Included

1/4"-20 x 3/4"
Carriage Bolt (3)



1/4"-20 x 3/8"
Round Head Bolt (3)



Washer (3)



Lock Washer (6)



Small Nut (3)



1/4"-20
Large Nut (6)



1/2"-13
3" Caster (6)



Axle (3)

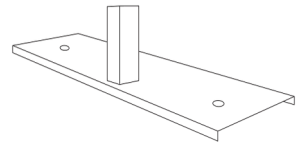

INSTALLATION INSTRUCTIONS

- 1) Bolt both sides of gate together at top and bottom.
(See Figure 1)

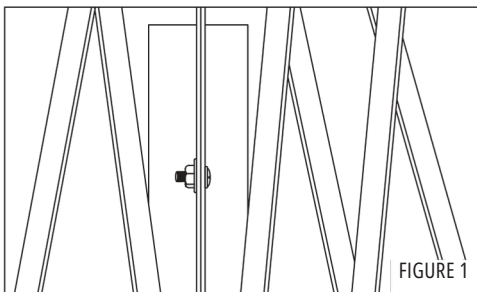

- 2) Insert each gate end into axle supports. Insert bolts and tighten.
(See Figure 2)

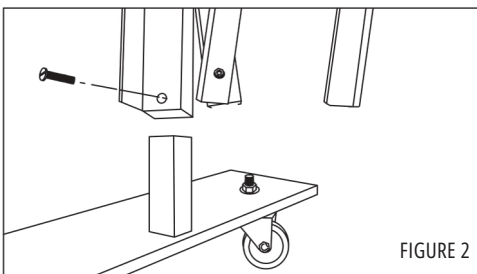

- 3) Thread washer onto each wheel bolt, insert through gate axle wheel hole, thread washer, insert brace, thread and tighten bolt. (See Figure 3)

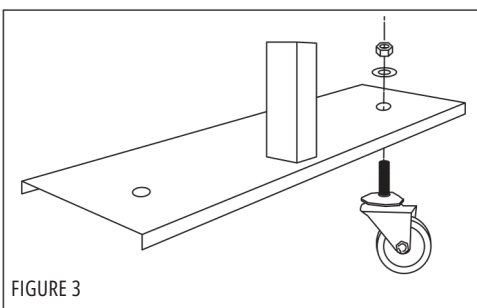

- 4) Collapse gate, lower gate axle locking bars into pins and roll gate to desired location.

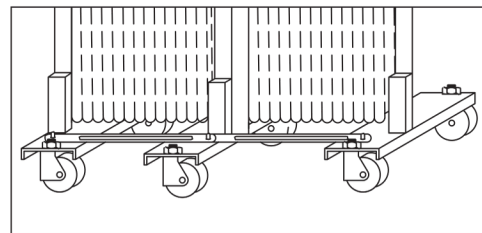

PORTABLE GATE ADD-ON:

Repeat steps 1-3 for each 6 foot add-on gate.



CAUTION! Pinch Point: Keep hands and fingers out of moving diamonds of web when handling gate.

4710 N Brady Street • DAVENPORT, IA 52806

• Barron Equipment • 800-397-6690 • 563-391-1321 FAX

Email SALES@BARRONEQ.COM