

# FLEXIBLE BOLLARD

ITEM NUMBER	QUANTITY	PART NUMBER	PART NAME	REVISDN	COMMENT
1	2	37030	HEX LOCKNUT-ZINC		
2	1	RE-SK	TORSION SPRING		
3	1	RE-8P	BASE PLATE		
4	4	33012	.5" FLAT WASHER-ZINC		
5	2	13824	3" HEX BOLT-ZINC		
6	2	11253669	10-6 X .5" TAP SCREW		
7	1	73780	5/16-1BX1 BUTT. CAP SCREW		
8	1	FP-RTC	BOLLARD CAP		
9	1	RE-FR-7	7" FOAM SPACER RING		
10	1	RE-47P	47" STEEL POST		
11	1	RE-8C[52]	IDEAL SHIELD BOLLARD COVER 52" X 7"		

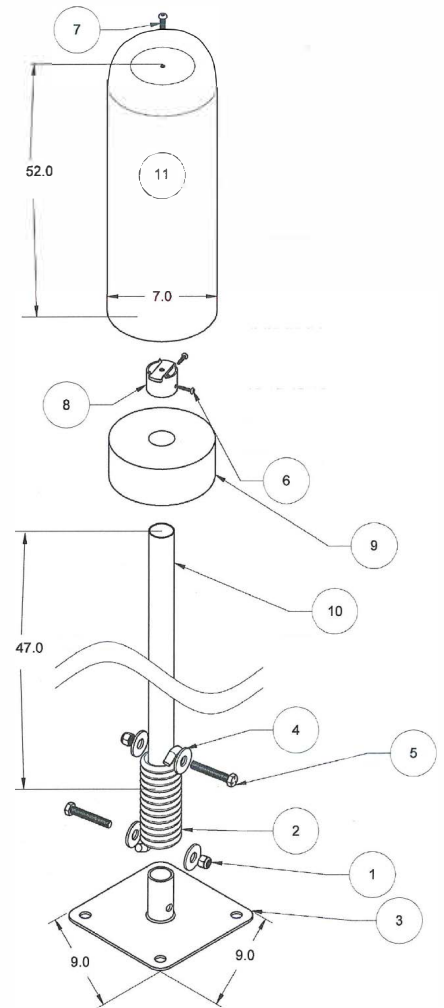

WWW.BARRONEQ.COM • (800) 397-6690 • PLEASE SUBMIT YOUR PRODUCT INQUIRY TO SALES@BARRONEQ.COM

THIS DRAWING AND ALL THE INFORMATION THEREON IS THE PROPERTY OF THE IDEAL SHIELD, IS CONFIDENTIAL AND MUST NOT BE MADE PUBLIC, NOR COPIED, NOR USED, TO THE DISADVANTAGE OF SAID IDEAL SHIELD AND IS SUBJECT TO RETURN ON DEMAND.

COPYRIGHT 2019, IDEAL SHIELD®

NO.	REVISIONS	DATE	APPROVED



4710 N Brady St,  
Davenport, IA 52806

PROJECT	CUSTOMER	DESCRIPTION	DRAWN BY:	APPROVED BY:	DATE:
FLEXIBLE BOLLARD					