

ALUMINUM HANDRAIL SPECS

Product Details:

Steel Pipe: 1 1/2" schedule 40 and schedule 80 Aluminum pipe

Standard Height: 42" [custom sizes available]

Fittings: 6063 Aluminum Alloy

Base Flanges: Aluminum Alloy 535 [ASTM B26]

Fasteners: 302 or 304 Stainless Steel

Color: Anodized Aluminum

Assembly: No welding or hot work

Installation Options: Cored, Plated, Side-Mount, Wall-Mount, or Non-Penetrating Base Plate

*Installation hardware not included

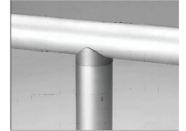
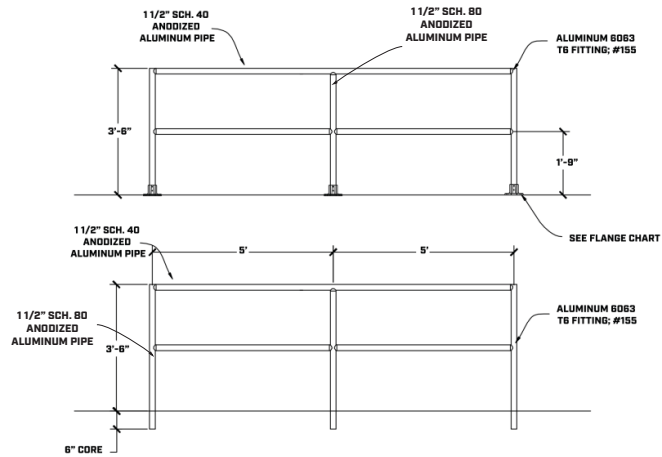

NO. 155 TEE

NOTES:
 *ALUMINUM B FITTINGS ARE FINISHED IN A CLEAR ANODIZE. POWDER COATING IS AVAILABLE.
 *4" ANODIZED ALUMINUM KICK PLATE (TOE PLATE) IS AVAILABLE.
 *CONTINUOUS ANODIZED ALUMINUM GRABRAIL ALSO AVAILABLE

Structural Performance:

Provide railings capable of withstanding the effects of gravity loads and the following loads and stresses within limits and under conditions indicated

Top Rails:

1. Concentrated load of 200 lbf (890 N) applied in any direction
2. Uniform load of 50 lbf/ft: (730 N/m) applied in any direction

Intermediate Rails:

1. Applied normal load of 50 pounds (0.22kn) on an area not to exceed 1 square foot including openings and space between rails

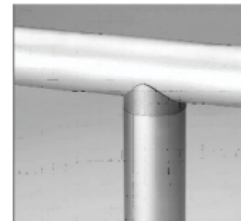
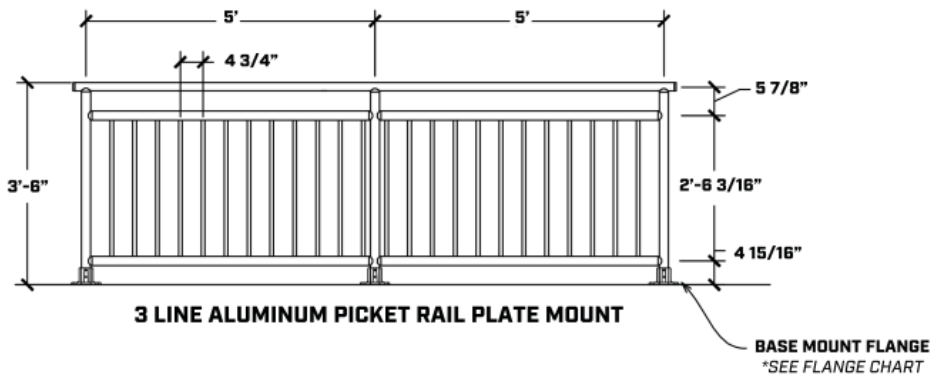

#155 TEE

