

LIFT-AND-DUMP HYDRAULIC DRUM DUMPERS - HLD-116-15-S

APPROX WEIGHT: 1212.00 lbs.
 DOES NOT INCLUDE WEIGHT OF POWER OR PACKAGING!!!

*** ANY ADDITIONS, DELETIONS, OR OMISSIONS MUST BE CORRECTED ON THIS DRAWING AS THIS DRAWING WILL BE CONSIDERED ALL INCLUSIVE ***
 ALL GRAPHICS PROVIDED ARE FOR REFERENCE ONLY. IF CERTAIN DIMENSIONS ARE CRITICAL PLEASE VERIFY THOSE DIMENSIONS WITH YOUR SALESPERSON

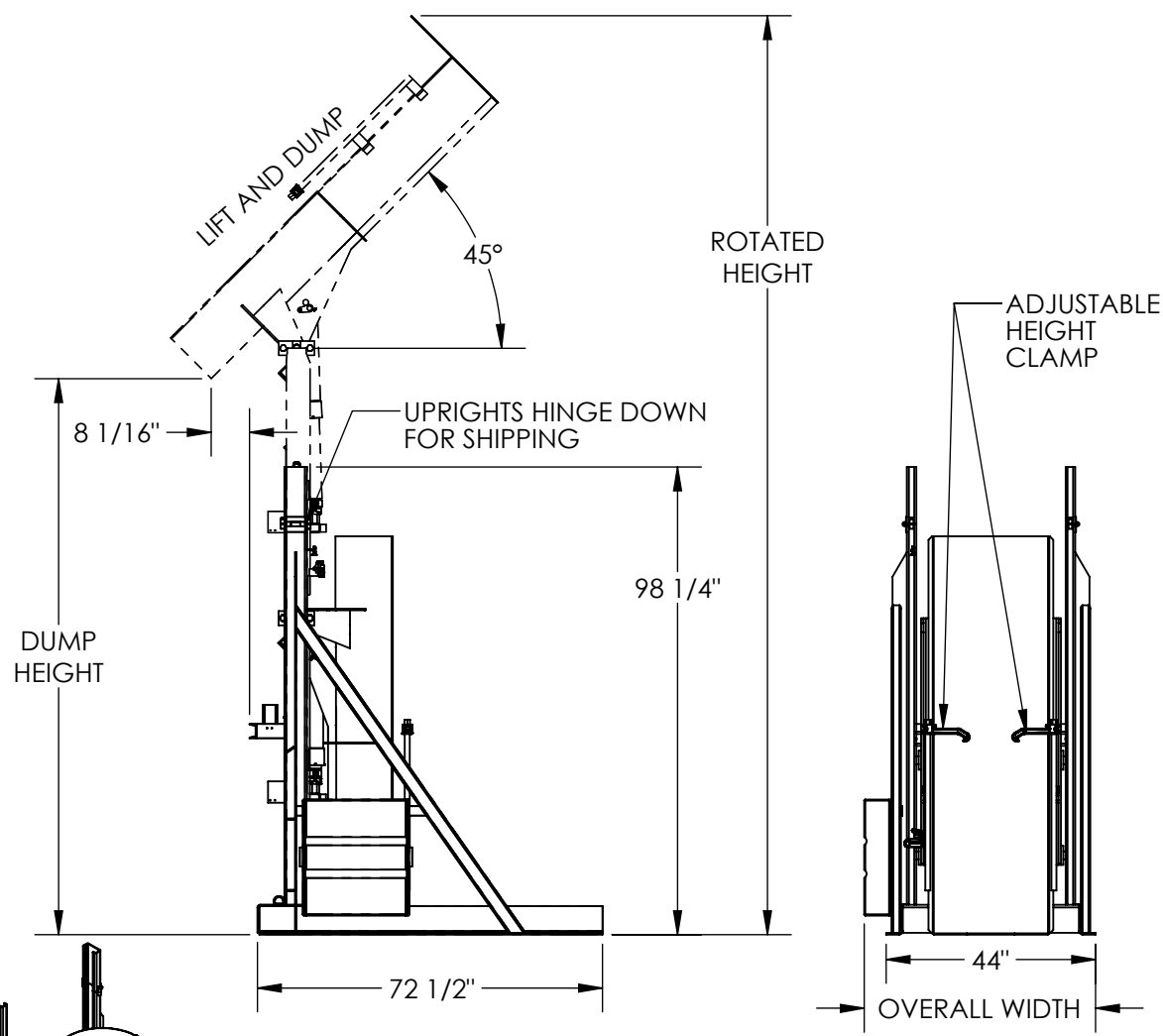

STANDARD FEATURES

- MODEL NUMBER IS HLD-116-15-S
- LIFT AND DUMP DESIGN
- INDEPENDENT LIFT AND DUMP OPERATION
- MAX. DUMP HEIGHT IS 116"
- MIN. DUMP HEIGHT IS 60"
- OVERALL WIDTH IS 51"
- OVERALL LENGTH IS 72 1/2"
- LEVEL HEIGHT IS 98 1/4"
- ROTATED HEIGHT IS 194"
- DUMP ANGLE IS 45°
- ACCEPTS DRUM SIZE: Ø16 1/2" TO Ø23 1/2" (ROUND) X 27 1/2" TO 39 1/2" TALL
- UNIT IS STATIONARY
- MAX CAPACITY IS 1,500 LBS.
- HANDHELD PUSH BUTTON CONTROL WITH 8 FT. EXTENDED COIL CORD
- DURABLE LIQUID PAINT BLUE FINISH FRAME
- DURABLE BAKED IN POWDER COATED YELLOW FINISH CHUTE
- 3000 PSI HYD. COMPONENT RATING
- WARNING: CHECK LOCAL AND STATE CODES!

SPECIAL FEATURES

NONE

DIMENSION TOLERANCE ± 1/4"

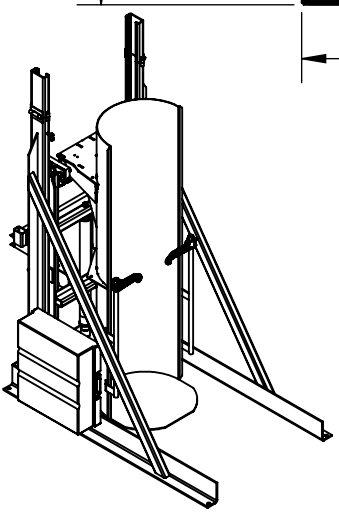

**460V 3 PHASE
 AC POWER**

CONTACT FACTORY FOR
 OTHER POWER OPTIONS

APPROVAL

I, THE UNDERSIGNED, AGREE THAT THE PRODUCT AS REPRESENTED SATISFIES DESIGN AND DIMENSION REQUIREMENTS. I ALSO ACKNOWLEDGE MY DUTY TO CONFIRM PRODUCT AND INSTALLATION COMPLIANCE WITH ALL APPLICABLE FEDERAL, STATE AND LOCAL REGULATIONS AND STANDARDS.

UNITS REQUIRING APPROVAL DRAWINGS OR MODIFIED ARE NON-RETURNABLE

As drawn As marked

Signed: _____ Date: _____

Printed Name: _____

LEAD TIME WILL START UPON RECEIPT OF SIGNED APPROVAL DRAWING

DISTRIBUTOR'S NAME:		P.O.#
VESTIL MANUFACTURING		X
DRAWN BY: CA		W.O.#
DATE: 09/02/2011		X
REFERENCE: X	SCALE: 1:40	SALES: X
QUOTED LEAD TIME: X	QUOTE #	FILE NAME:
	X	09-007-098-001