

SINGLE ROW, FLAT TOP LOCKERS

GENERAL INSTRUCTIONS:

- 1) PLEASE READ COMPLETE ASSEMBLY INSTRUCTIONS BEFORE ATTEMPTING TO ASSEMBLE LOCKERS. FOR ACCESSORIES, SEE SHEET 3.
- 2) CHECK THE MATERIAL TO BE SURE THAT IT IS CORRECT FOR THE JOB AND THAT THERE IS NO DAMAGE.
- 3) BE CAREFUL TO USE THE CORRECT HARDWARE SPECIFIED. USE BOLT NO. 1 ALL AROUND WITH BOLT HEADS OUT EXCEPT AS NOTED.
- 4) LOCKERS SHOULD BE ASSEMBLED IN GROUPS AS INDICATED ON THE ORDER OR DRAWINGS.
- 5) THE ESSENTIAL TOOLS REQUIRED FOR ASSEMBLING LOCKERS ARE: A REGULAR SCREWDRIVER, TWO DRIFT PINS (OR TWO NAIL PUNCHES) FOR HOLE ALIGNMENT, AND A 3/8" SOCKET WRENCH.
- 6) LOCKERS SHOULD BE ASSEMBLED ON A FLAT LEVEL SURFACE AND ANCHORED PER SHEETS 5 & 6.

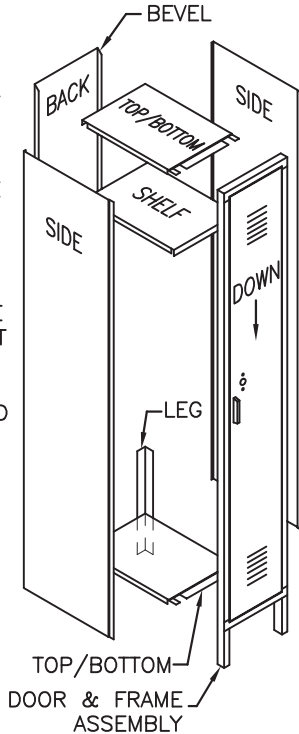

OPERATION #2

BOLT A SIDE, WITH FLANGE IN, TO OPERATION #1 ASSEMBLY (OMIT 2 BOLTS NEAR BOTTOM REAR FOR LEGS, IF REQUIRED). BOLT A SHELF WITH FLANGES DOWN & 45° FLANGE IN FRONT, TO THE SIDE AT DESIRED LOCATION (E.G. 9", 12", ETC.).

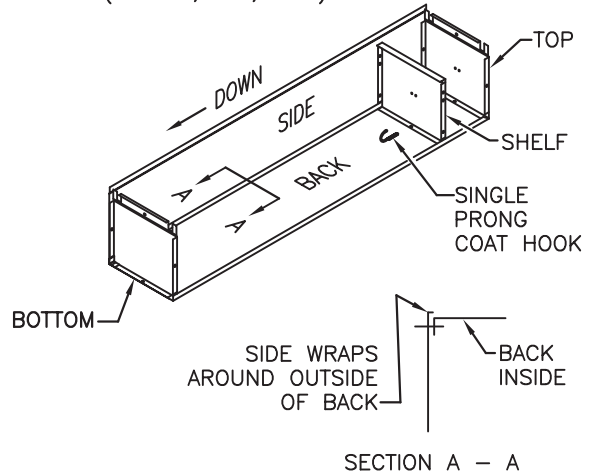

OPERATION #3

BOLT SIDE HOOKS IN PLACE BELOW SHELF (USE NO. 2 BOLTS FOR HOOKS TO BE BACK TO BACK WITH THE SIDE BETWEEN EACH COMPONENT). USE NO. 1 BOLTS ON TOPS, BOTTOMS, SHELVES AND BACKS. PLACE EACH OF THE ABOVE COMPONENTS SIDE TO SIDE WITH A LOCKER SIDE SHEET BETWEEN AND BOLT IN PLACE. ATTACH COAT RODS IF REQUIRED (SEE ACCESSORIES PAGE). REPEAT THIS OPERATION UNTIL REQUIRED LOCKER UNITS ARE ASSEMBLED.

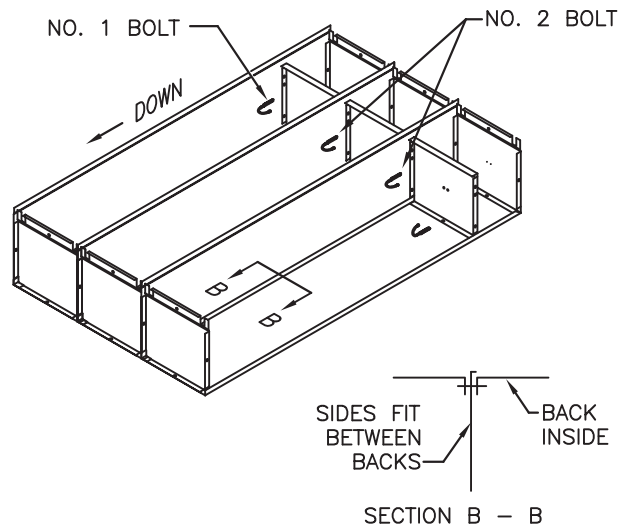

HARDWARE:

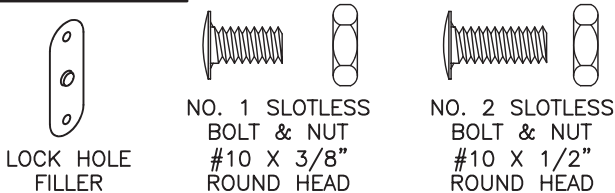

NOTE: FOR HEAVY DUTY LOCKERS, USE NO. 2 BOLT ONLY.

OPERATION #1

BOLT A TOP, BOTTOM, AND HOOK TO A BACK. THE TOP AND BOTTOM (IDENTICAL) MUST HAVE FLANGES DOWN. BACK TO HAVE FLANGES UP & FLANGE BEVEL AT TOP. HOOK TO MOUNT BELOW SHELF LOCATION.

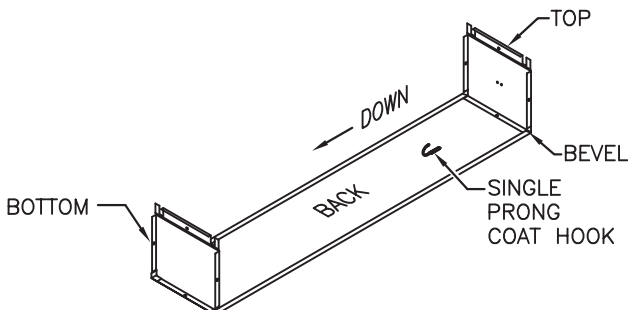

E-061201-1

**MISSING PARTS OR IN NEED
OF
ASSEMBLY ASSISTANCE?**

Contact us direct for fast friendly service (800) 397-6690
www.barroneq.com

ASSEMBLY INSTRUCTIONS
FOR LYON SINGLE ROW
FLAT TOP STEEL LOCKERS

6225-CA
SHEET 1 OF 6

OPERATION #4

ADD A LAST SIDE, WITH FLANGE IN, TO OPERATION #3 ASSEMBLY. INSERT REAR LEGS, IF REQUIRED, IN EACH END OF LOCKER AT 36" MAXIMUM SPACING, AND BOLT IN LEAVING BOLTS LOOSE. ADD A DOUBLE PRONG HOOK UNDER EACH SHELF AND ADD A SINGLE PRONG HOOK TO THE LAST SIDE.

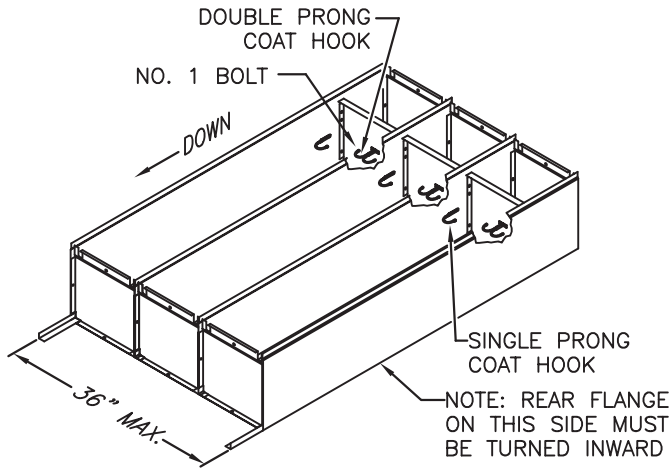

OPERATION #5

ATTACH DOOR AND FRAME ASSEMBLIES TO LOCKERS BEING SURE THE SIDE IS NEVER BETWEEN FRAMES (SEE SECTION A-A). LEAVE TOP, CENTER AND BOTTOM BOLTS OUT ON EXTREME ENDS OF GROUPS FOR ATTACHING FILLERS OR ADDITIONAL GROUPS. USE DRIFT PINS (OR NAIL PUNCHES) TO ALIGN TOP & BOTTOM HOLES OF FRAME.

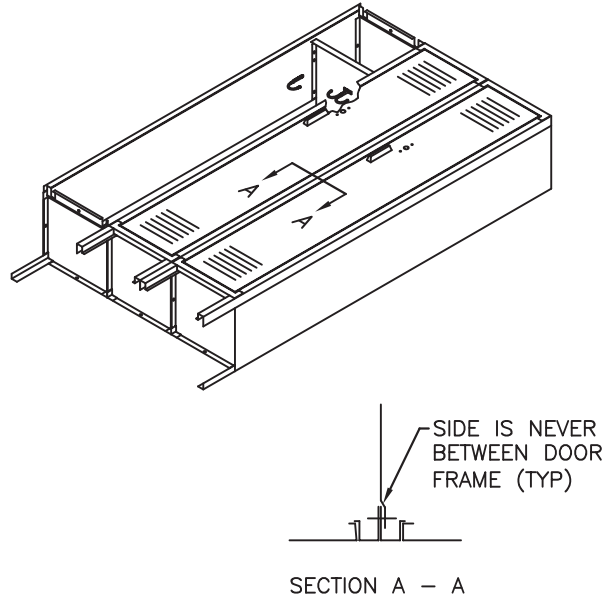

OPERATION #6

STAND GROUPS IN PLACE. LEVEL THEM AND ADJUST REAR LEGS TO TOUCH FLOOR AND TIGHTEN BOLTS. BOLT GROUPS TOGETHER USING BOLTS OMITTED IN OPERATION #5. ATTACH LOCK HOLE FILLERS AS REQUIRED.

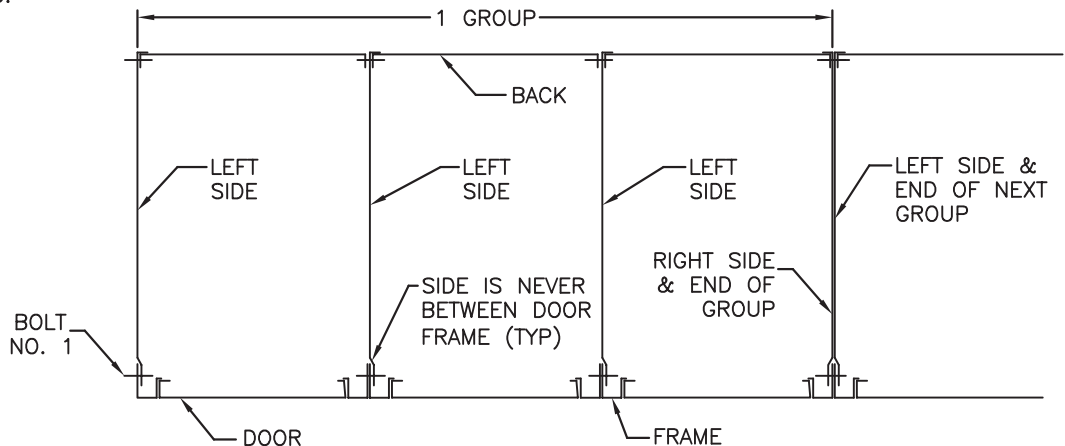

ADJACENT DOOR FRAMES OF GROUPS

E-010120-2

**MISSING PARTS OR IN NEED
OF
ASSEMBLY ASSISTANCE?**

Contact us direct for fast friendly service (800) 397-6690

www.barroneq.com

ASSEMBLY INSTRUCTIONS
FOR LYON SINGLE ROW
FLAT TOP STEEL LOCKERS

6225-CA
SHEET 2 OF 6

ACCESSORIES

COAT ROD

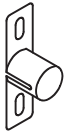

COAT ROD CLIP

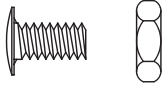

NO. 1 SLOTLESS
BOLT & NUT
#10 X 3/8"
ROUND HEAD

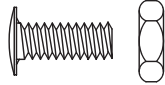

NO. 2 SLOTLESS
BOLT & NUT
#10 X 1/2"
ROUND HEAD

COAT RODS ARE ATTACHED TO THE LOCKER SIDES WITH A COAT ROD CLIP AS SHOWN

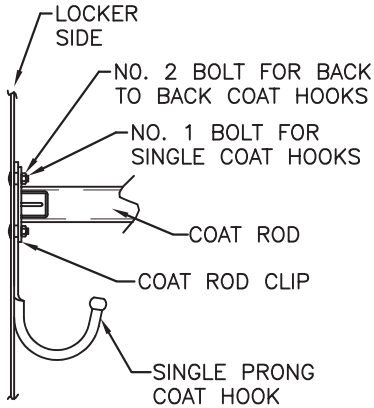

CLOSED FRONT & END BASES

IF THE SPACE BETWEEN THE BOTTOM OF THE LOCKERS AND THE FLOOR IS TO BE CLOSED, FRONT AND END BASES MUST BE ORDERED.

1) END BASES MUST BE ATTACHED BEFORE THE LOCKER FOOT IS ATTACHED. END BASES SLIDE UP OVER THE FRONT AND REAR LEGS OF THE END LOCKERS.

2) A FRONT BASE IS INSTALLED BY SETTING IT IN POSITION AND PUSHING IT BACK UNTIL THE EMBOSSEMENTS SNAP INTO THE LOCKER LEG.

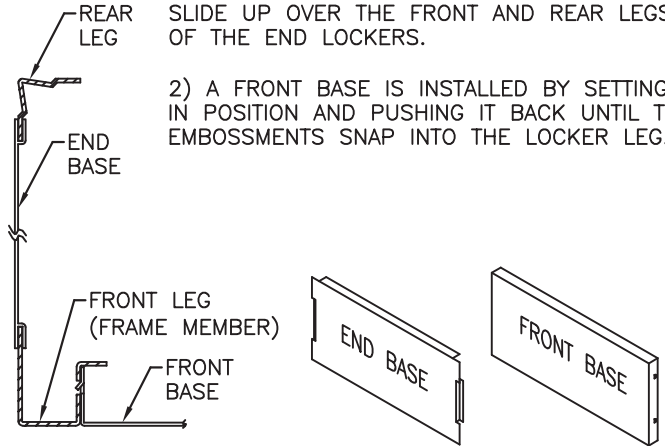

LOCKER NUMBER PLATES



NO. 4
3/32" DIA. POP RIVET



POP RIVET GUN REQUIRED.
(NOT FURNISHED)

E-010120-2

**MISSING PARTS OR IN NEED
OF
ASSEMBLY ASSISTANCE?**

Contact us direct for fast friendly service (800) 397-6690

www.barroneq.com

ACCESSORIES
FOR LYON
STEEL LOCKERS

6225-CA
SHEET 3 OF 6

PUNCHING PATTERNS

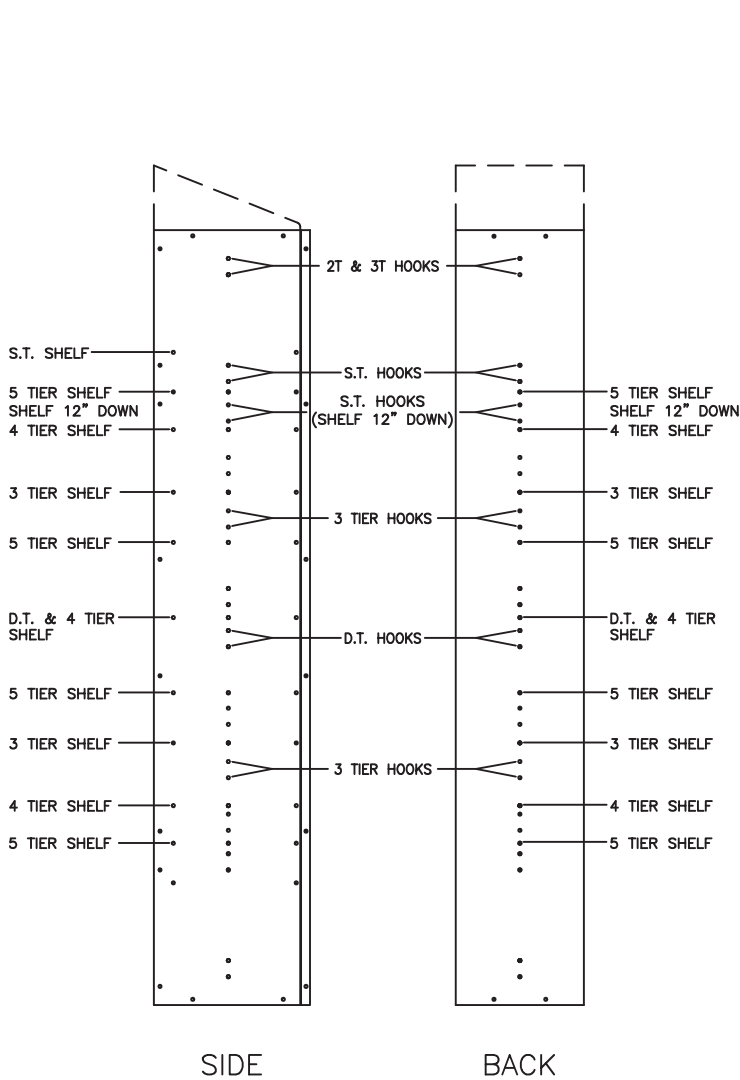

**60" FLAT & SLOPING
UNIVERSAL SIDES & BACKS**

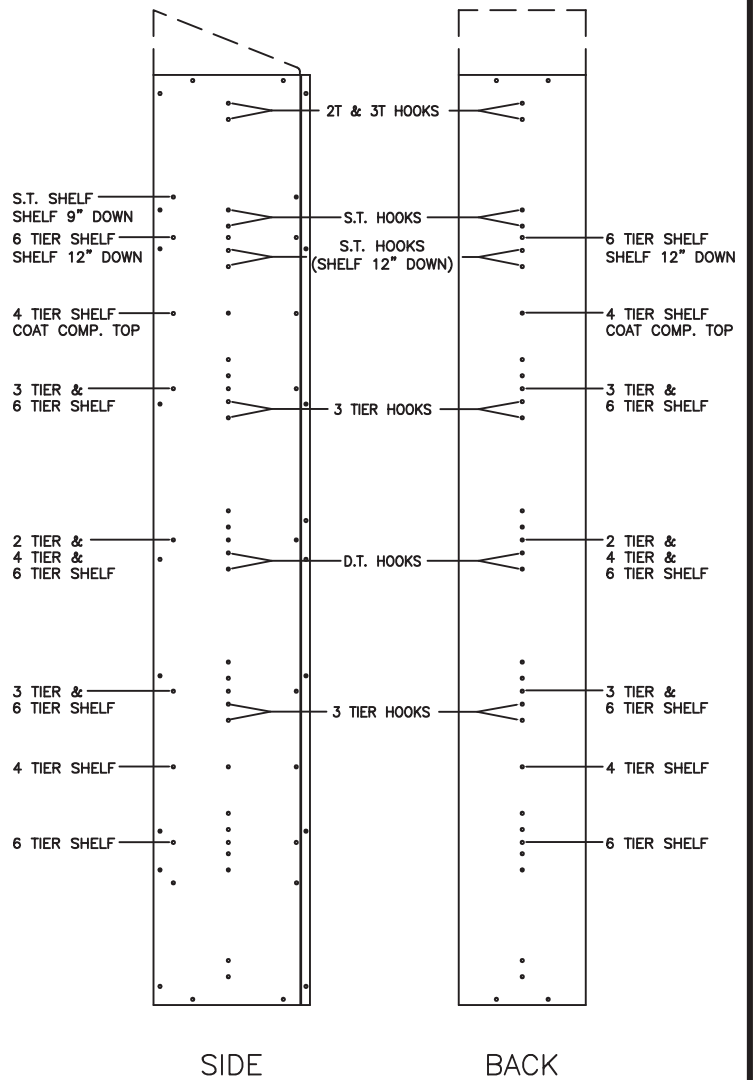

**72" FLAT & SLOPING
UNIVERSAL SIDES & BACKS**

E-010120-2

**MISSING PARTS OR IN NEED
OF
ASSEMBLY ASSISTANCE?**

Contact us direct for fast friendly service (800) 397-6690

www.barroneq.com

PUNCHING PATTERN
FOR LYON
STEEL LOCKERS

6225-CA
SHEET 4 OF 6

RECOMMENDED ANCHORING METHODS

(ANCHORS NOT FURNISHED BY LYON)

ANCHORS FOR MASONRY:

MIN. PULL-OUT
VALUE IN LBS.

- 3/16" SPRING WING TOGGLE BOLT-----200
- 9/64" DIA. HAMMER-IN DRIVE PINS
 3/4" PENETRATION-----400
- 3/16" X 7/8" NAIL DRIVE ANCHORS-----500
- 1/4" SPRING WING TOGGLE BOLT-----650
- RAWPLUGS & #8 SHT. METAL SCREWS
 1" PENETRATION-----1190
- EXPANSION SCREWS FOR #10-24 SCREWS
 (MIN. LENGTH 5/8")-----1340
- 1/4" X 1 1/8" ONE PIECE ANCHOR BOLT-----1650
- 1/4" X 1 3/4" STUD ANCHORS-----1700

ANCHORS FOR WOOD:

MIN. PULL-OUT
VALUE IN LBS.

- .216" (#12) WOOD SCREWS
 1" PENETRATION (2 REQ'D)-----120
- 1 1/2" PENETRATION-----180
- .242" (#14) WOOD SCREWS
 1" PENETRATION (2 REQ'D)-----135
- 1 1/2" PENETRATION-----202
- 1/4" DIA. LAG BOLT
 1" PENETRATION-----185
- 1 1/2" PENETRATION-----277
- 5/16" DIA. LAG BOLT
 1" PENETRATION-----220
- 1 1/2" PENETRATION-----330

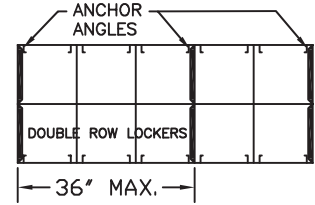
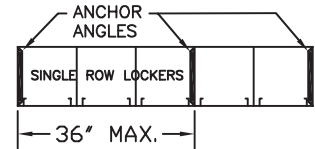

NOTE:

1) EXTREME END LOCKERS TO BE ANCHORED PLUS INTERMEDIATE LOCKERS ON 36" CENTERS MAX.

2) ALL BANKS OF LOCKERS TO BE TIED TOGETHER IN A MINIMUM OF 2 PLACES PER LOCKER. #10-24 NUTS & BOLTS CAN BE USED. RIVETS MAY NEED TO BE REMOVED FROM ATTACHING HOLES ON SET-UP LOCKERS.

POWER ACTUATED ANCHORS:

- 9/64" DIA. DRIVE PIN
 3/4" PENETRATION-----315
- 5/32" DIA. DRIVE PIN
 1" PENETRATION-----415

WARNING:
 -FLOOR ANCHOR MUST HAVE A MINIMUM PULL-OUT VALUE OF 190 LBS.
 -WALL ANCHOR MUST HAVE A MINIMUM PULL-OUT VALUE OF 150 LBS.

FREE STANDING SINGLE ROW LOCKERS WITH 6" LEGS

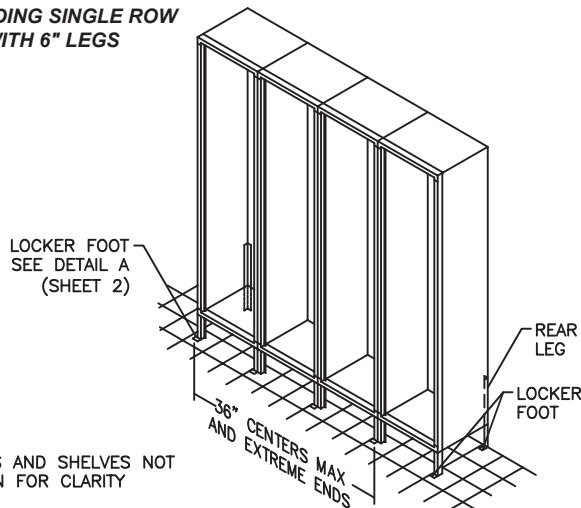

DOORS AND SHELVES NOT SHOWN FOR CLARITY

FREE STANDING SINGLE ROW LOCKERS

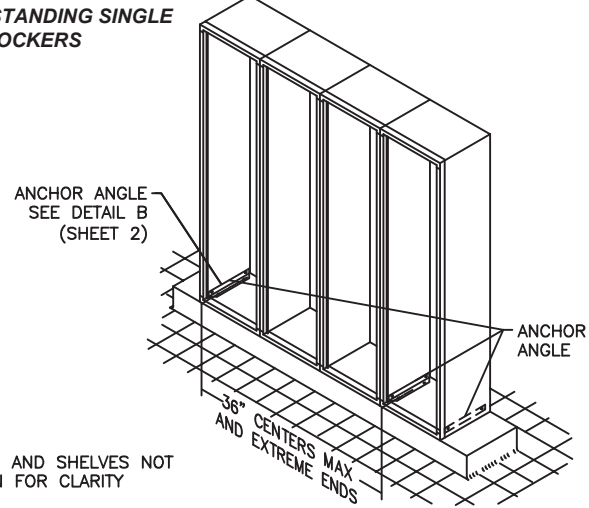

DOORS AND SHELVES NOT SHOWN FOR CLARITY

SINGLE ROW LOCKERS WITH 6" LEGS AGAINST A WALL

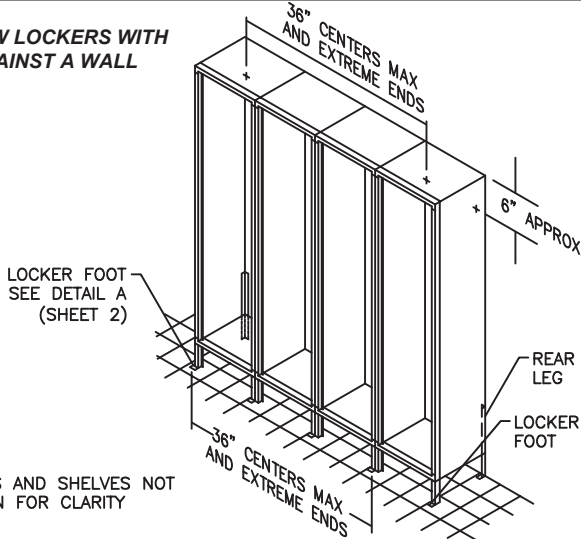

DOORS AND SHELVES NOT SHOWN FOR CLARITY

SINGLE ROW LOCKERS AGAINST A WALL

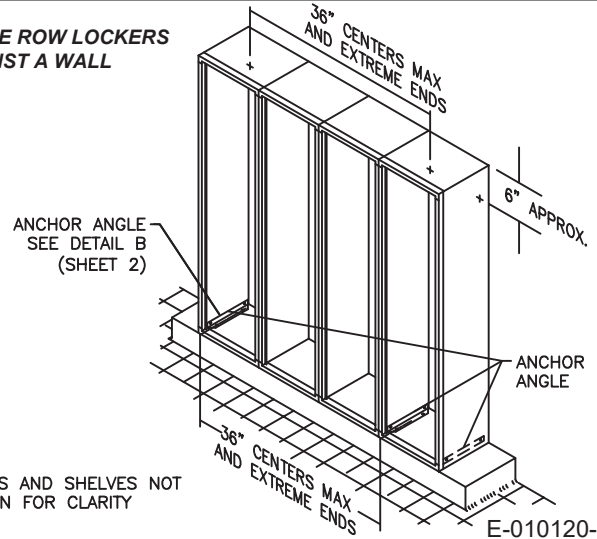

DOORS AND SHELVES NOT SHOWN FOR CLARITY

E-010120-2

**MISSING PARTS OR IN NEED
 OF
 ASSEMBLY ASSISTANCE?**

Contact us direct for fast friendly service (800) 397-6690
www.barroneq.com

ANCHORING INSTRUCTIONS
 FOR LYON
 STEEL LOCKERS

6225-CA
 SHEET 5 OF 6

FREE STANDING DOUBLE ROW LOCKERS WITH 6" LEGS

DOORS AND SHELVES NOT SHOWN FOR CLARITY

LOCKER FOOT SEE DETAIL A

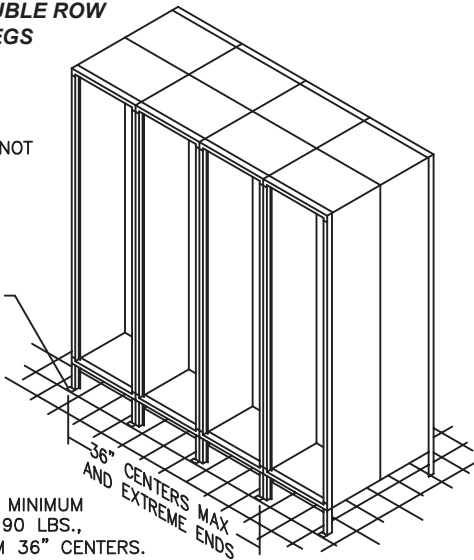

WARNING:
ANCHOR MUST HAVE A MINIMUM PULL-OUT VALUE OF 190 LBS., SPACED ON A MAXIMUM 36" CENTERS.

FREE STANDING DOUBLE ROW LOCKERS

DOORS AND SHELVES NOT SHOWN FOR CLARITY

ANCHOR ANGLES SEE DETAIL B

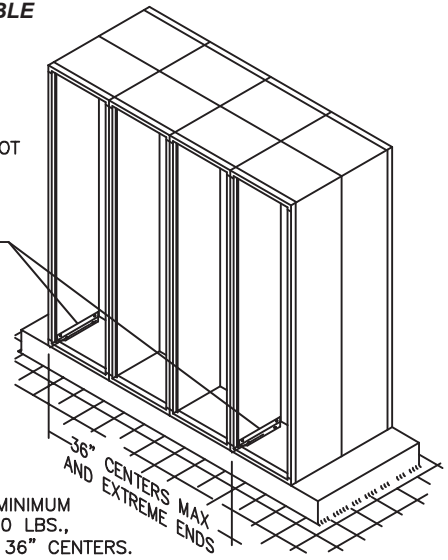

WARNING:
ANCHOR MUST HAVE A MINIMUM PULL-OUT VALUE OF 190 LBS., SPACED ON A MAXIMUM 36" CENTERS.

SET-UP AND ALL-WELDED LOCKERS WITH & WITHOUT 6" LEGS (LEGS SHOWN)

DOORS AND SHELVES NOT SHOWN FOR CLARITY

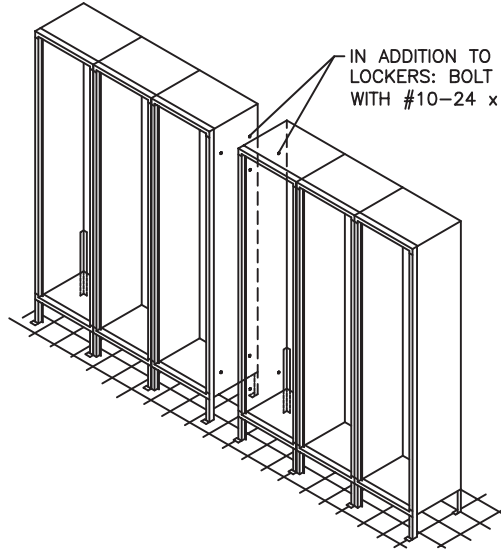

IN ADDITION TO THE INSTRUCTIONS FOR ANCHORING LOCKERS: BOLT GROUPS SIDE BY SIDE IN 4 PLACES WITH #10-24 x 1/2" SCREWS AND KEP NUTS.

DETAIL A LOCKER FOOT ASSEMBLY

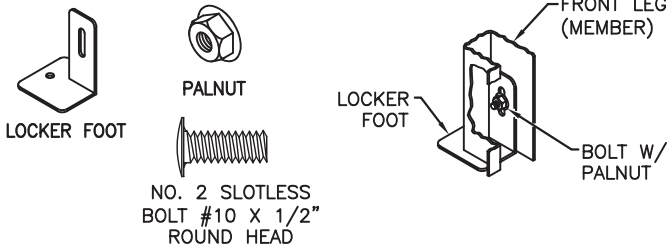

ATTACH A LOCKER FOOT TO EACH FRONT LEG AS SHOWN. USE A NO. 2 BOLT AND A PALNUT. IF END BASES ARE USED, THEY MUST BE ATTACHED BEFORE THE LOCKER FOOT.

NOTE: DRAW NUT UP TIGHT AFTER LOCKERS ARE SET IN PLACE AND LEVELED.

DETAIL B LOCKER ANCHOR ANGLE

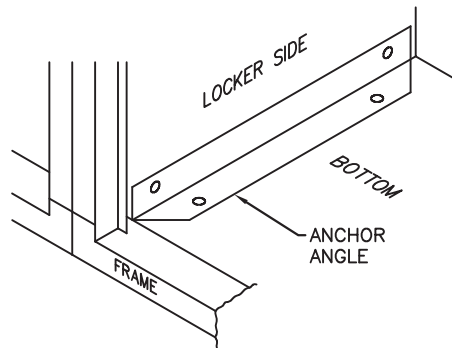

1) CONNECT ANCHOR ANGLE TO LOCKERS WITH CONSTRUCTION BOLTS AND NUTS.

2) DRILL ANCHOR ANGLE AND SECURE LOCKER THRU BOTTOM. USE AN ANCHOR THAT IS RECOMMENDED BY LYON FOR MIN. PULL OUT VALUE. (SEE CHART)

E-010120-2

MISSING PARTS OR IN NEED OF ASSEMBLY ASSISTANCE?

Contact us direct for fast friendly service (800) 397-6690
www.barroneq.com

ANCHORING INSTRUCTIONS FOR LYON STEEL LOCKERS

6225-CA
SHEET 6 OF 6