

4

3

2

1

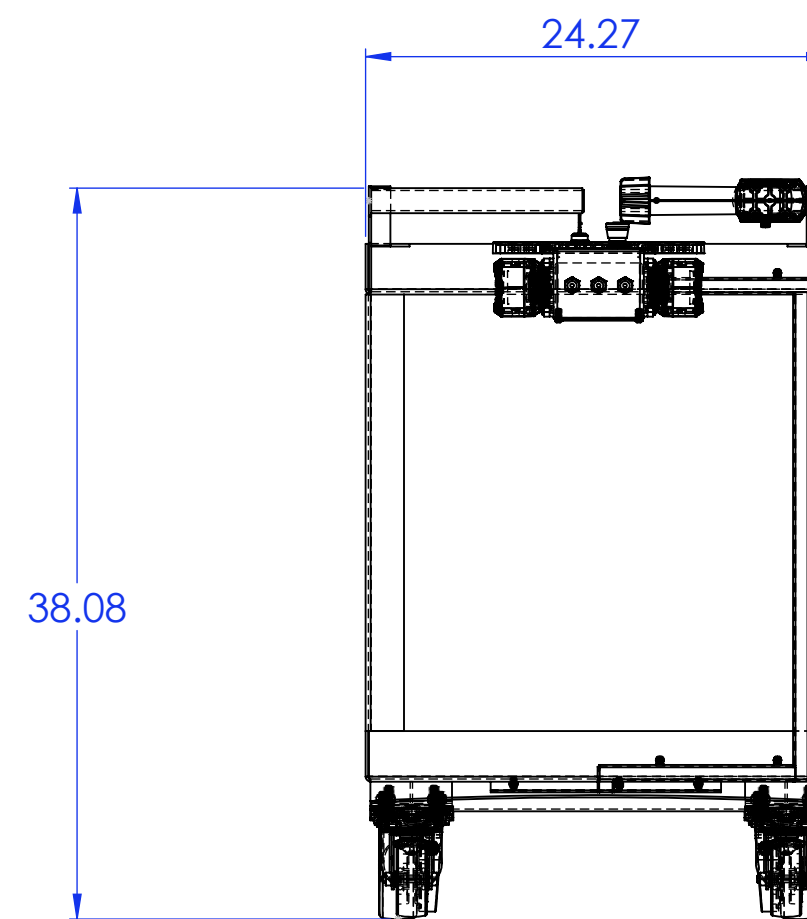
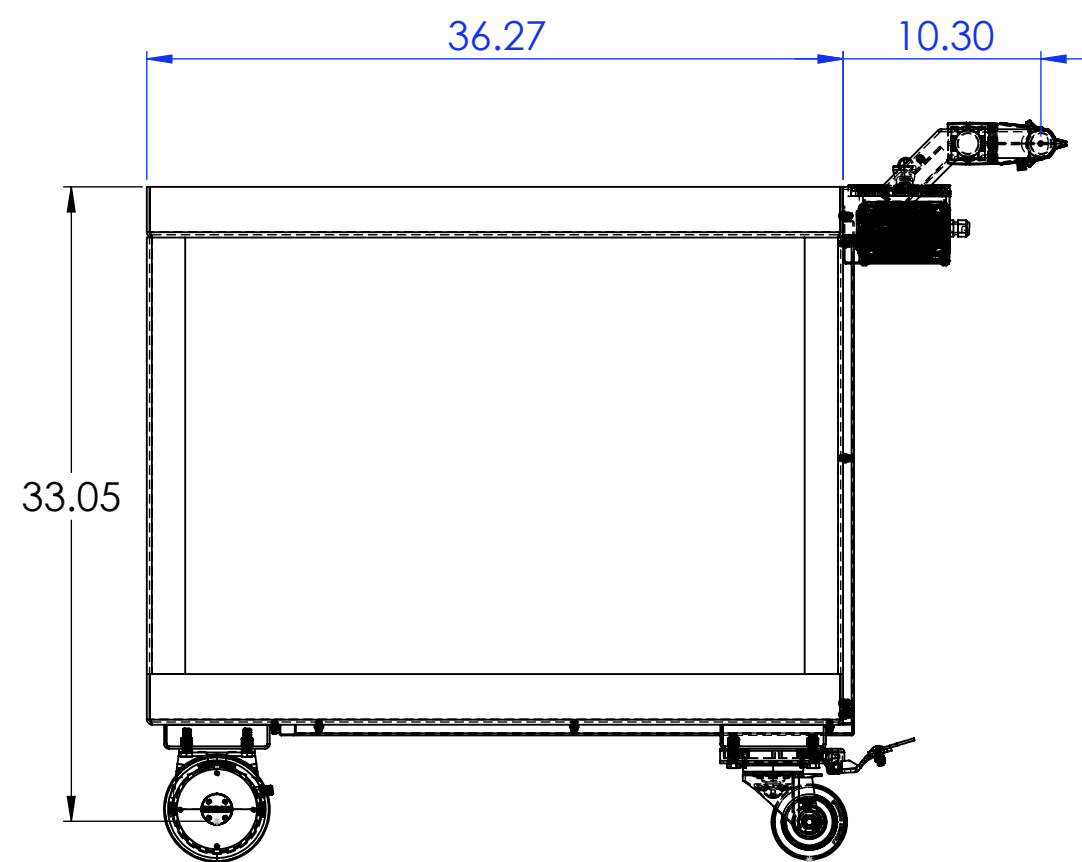
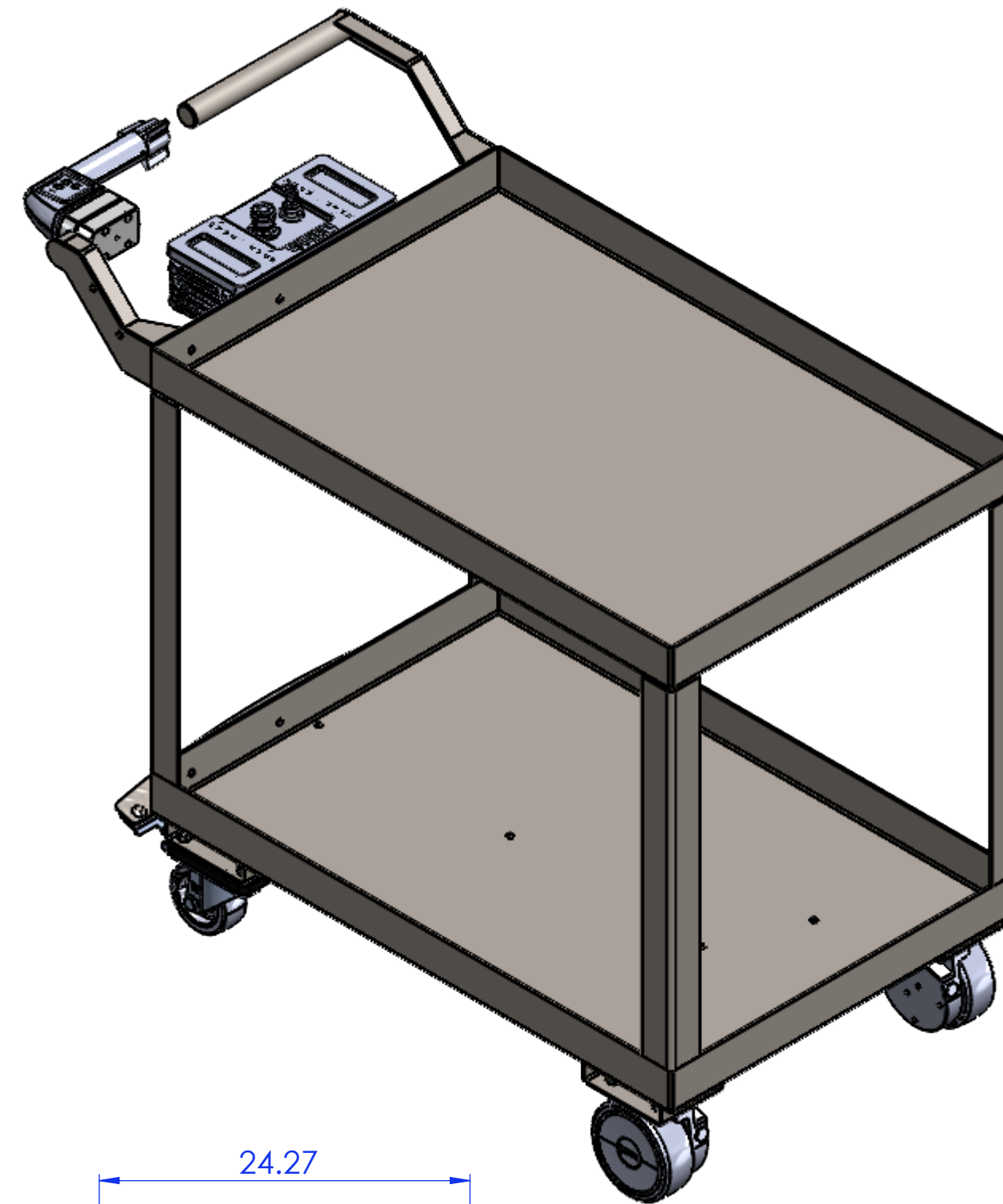

UNLESS OTHERWISE SPECIFIED, DIMENSIONS ARE IN INCHES.
 INTERPRET DIMENSIONS AND TOLERANCES PER ASME Y14.1-2012.

STANDARD TOLERANCES

X.X	± 0.060
X.XX	± 0.030
X.XXX	± 0.010
FRACTION DIMS:	± 1/32
ANGLES:	± 1°
SURFACE FINISH:	125

THIRD ANGLE PROJECTION

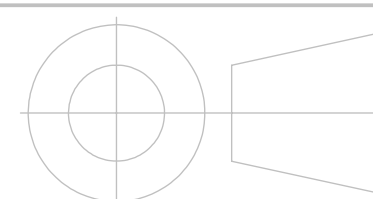

DESIGN CONTROL

TASK	NAME	DATE
DESIGNED BY	TLG	10/23/2025
DRAWN BY	TLG	10/23/2025
APPROVED BY	TLG	10/23/2025

DOCUMENT CONTROL

SHEET SCALE	1:5
SHEET SIZE	C
SHEET NO	#1 OF #1



PART NO

BE.CART.ERGO

REV

A

4

3

2

1

D

D

C

C

B

B

A

A