

## DOCK BOARD, DOCK PLATE & CONTAINER RAMP SELECTION GUIDE



### Container Ramps MODEL CR

**For:**

- Loading and unloading containers
- Accessing ground level containers

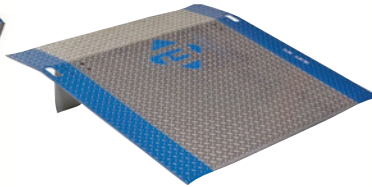

### Aluminum Dock Plates MODEL A/B

**For:**

- Non-powered pallet jack, hand truck and cart use
- Corrosive environments

**Not for:**

- Below dock conditions

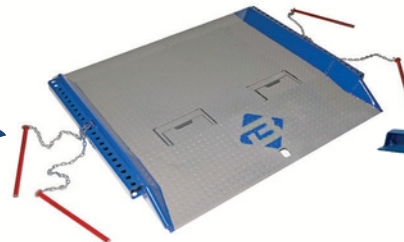

### Red Pin Steel Dock Boards MODEL C

**For:**

- High to medium volume applications
- Difficult trailer to dock positions
- Park out situations

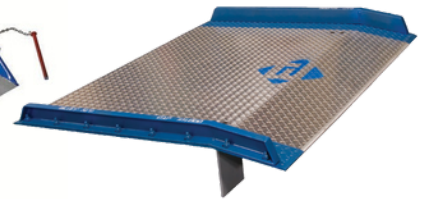

### Aluminum Dock Boards MODEL AC/BC

**For:**

- Low to medium volume applications
- Corrosive environments

**Not for:**

- Below dock conditions



### Steel Truck Dock Boards MODEL T

**For:**

- Medium to high volume applications
- Below dock conditions
- Loading and unloading dock level containers
- Higher capacity applications (15,000+)

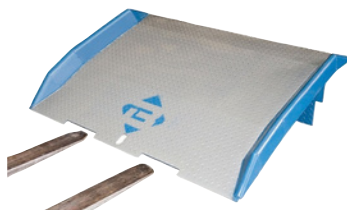

### Steel Speedy Boards® MODEL SB

**For:**

- High, medium or low volume applications
- Increased productivity (operator does not need to dismount for placement)
- Safety gains (operator does not need to leave the safety of the cage)

**Not for:**

- Below dock conditions

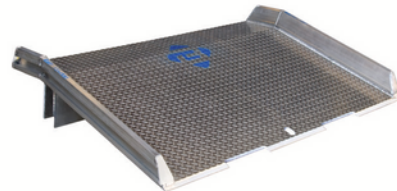

### All Aluminum Dock Boards MODEL ATD

**For:**

- Low to medium volume applications
- Corrosive environments
- Combustible environments
- Lowest weight board available

**Not for:**

- Below dock conditions

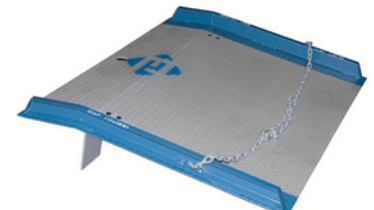

### Steel Dock Boards MODEL SC

**For:**

- Low to medium volume applications
- Lighter weight capacities (10-13,000K)

**Not for:**

- Below dock conditions

## Choosing Length, Width and Capacity

Choosing the correct length, width and capacity of your loading dock equipment helps improve loading dock operations. The following guidelines will help determine the proper dock equipment.

### Length

To determine the proper dock board, plate or ramp, collect the following information:

- Dock or Ramp height (D)
- Height of highest truck (T) (Note: most standard trailers are 55", most refrigerated and container trailers are 59")
- Type of loading equipment used

### Dock Board, Plate or Ramp Length

Dock height (D) and Height of highest truck (T) will be used to calculate the Height Differential, which determines the length of the board. To determine the height differential, fill out the Height Differential chart. Use the Dock Plate and the Dock Board or Container Ramp Charts below to determine proper length.

### Dock Board, Plate and Ramp Width

Bluff recommends a minimum product width of 12"-18" wider than the overall width of the forklift or pallet used. For improved end loading efficiency, consider increasing board width. The diagram beside shows the extra room provided with increasing board width.

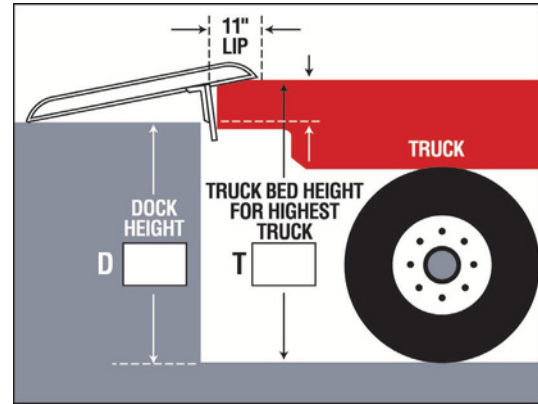

Height Differential	
<b>Highest Truck Height T</b> We recommend using 55" for the T unless your customer says otherwise, since 55" is the maximum height of most trailers. On refrigerated or container trailers use 59".	T = <input type="text"/> Inches
<b>Dock Height D</b> (You must measure this.)	- D = <input type="text"/> Inches
<hr/>	
	H = <input type="text"/> Inches

#### Height Differential (Maximum) H

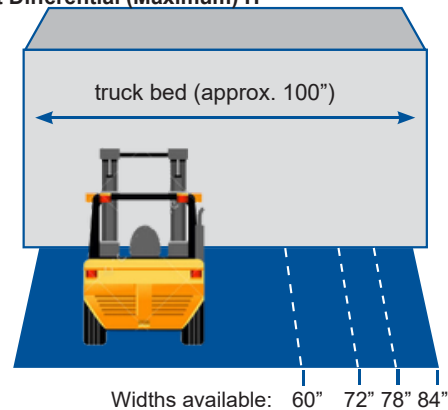

### Dock Plate

Height Differential	Dock Plate Length
1"	24"
2"	30"
3"	36"
4"	42"
5"	48"
6"	54"
7"	60"
8-8 1/2"	72"

### Dock Board or Container Ramp

Height Differential	Dock Board Length	
	Propane Forklift	Electric Forklift
3	36"	36"
5	36"	48"
7	48"	60"
9	60"	78"
11	72"	90"
13	84"	-
15	96"	-

## Dock Board or Ramp Capacity

To determine the proper capacity for your board or ramp, determine the forklift capacity that will be using the board or ramp. Review the following chart to find the type of forklift and match that with the correct board or ramp capacity.

3-Wheel Forklift Capacity	4-Wheel Forklift Capacity	Board/Ramp Capacity
2,000-2,500	2,000-3,000	10,000
-	3,000-4,000	13,000
3,000-3,500	5,000	15,000
4,000-5,000	5,000-6,000	20,000
6,000	7,000-8,000	25,000
6,500-7,000	8,500-10,000	30,000
8,000-10,000	10,000-13,000	40,000

- Stackers and other narrow aisle loaders should not be used on a dock board
- For Paper roll clamp and multi-shift loading add 5,000 pounds to the board capacity
- Capacity rated for single-shift operation at a 3 mile per hour maximum rate of travel

## Dock Plate Capacity

- Capacity is equal to the heaviest load transported
- To increase usability life increase capacity