

## BARRON ERGO CART

The Barron Ergo Cart is designed to reduce physical strain and improve workplace efficiency by providing a safer, more ergonomic way to transport materials in industrial environments.



### Features

- Battery-powered electric utility cart for ergonomic order picking
- Powered by the Blicke ErgoMove® 500 drive system
- Handles loads up to 1,100 lbs
- Integrated braking system for secure positioning
- Durable powder-coated 10-gauge steel construction
- Includes (2) 18V batteries and charger
- Easy to maneuver through narrow aisles and long distances

### Key Benefits

- Reduces strain on backs, shoulders, and arms
- Improves workplace ergonomics and worker comfort
- Helps prevent injuries related to repetitive material handling
- Increases productivity with easier, controlled transport
- Supports safer, more efficient workflows

### Ideal Applications

- Warehouses and distribution centers
- Manufacturing facilities
- Assembly and packaging areas
- Facilities prioritizing ergonomics and safety

**TECHNICAL SPECIFICATIONS ON REVERSE SIDE**

(800)397-6690 • 4710 N Brady St • Davenport, IA 52806 • [www.barroneq.com](http://www.barroneq.com)

## Technical Specifications

- Load Capacity:
  - 1100 Lbs
- Overall Dimensions (L x W x H):
  - 47.57 in L x 24.27 in. W x 38.08 in. H

## Construction & Components

- Frame Material:
  - 10-gauge steel
- Finish / Coating:
  - Powder-coated steel
- Casters:
  - 2 - 4 Inch x 1-9/16 Inch Swivel Casters with Polyurethane Elastomer Wheels
  - 2 - 5-1/2 Inch x 2 Inch electrically driven rigid casters
- Handle:
  - Handle with Rotary Joystick
- Brakes:
  - Integrated Brake System utilizing Ideal Stop Brakes on Swivel Casters

## Ordering Information

- Model Number:
  - BE.CART.ERGO



Learn More!

Ergonomic material handling cart designed for safe, efficient transport of materials in industrial and warehouse environments.

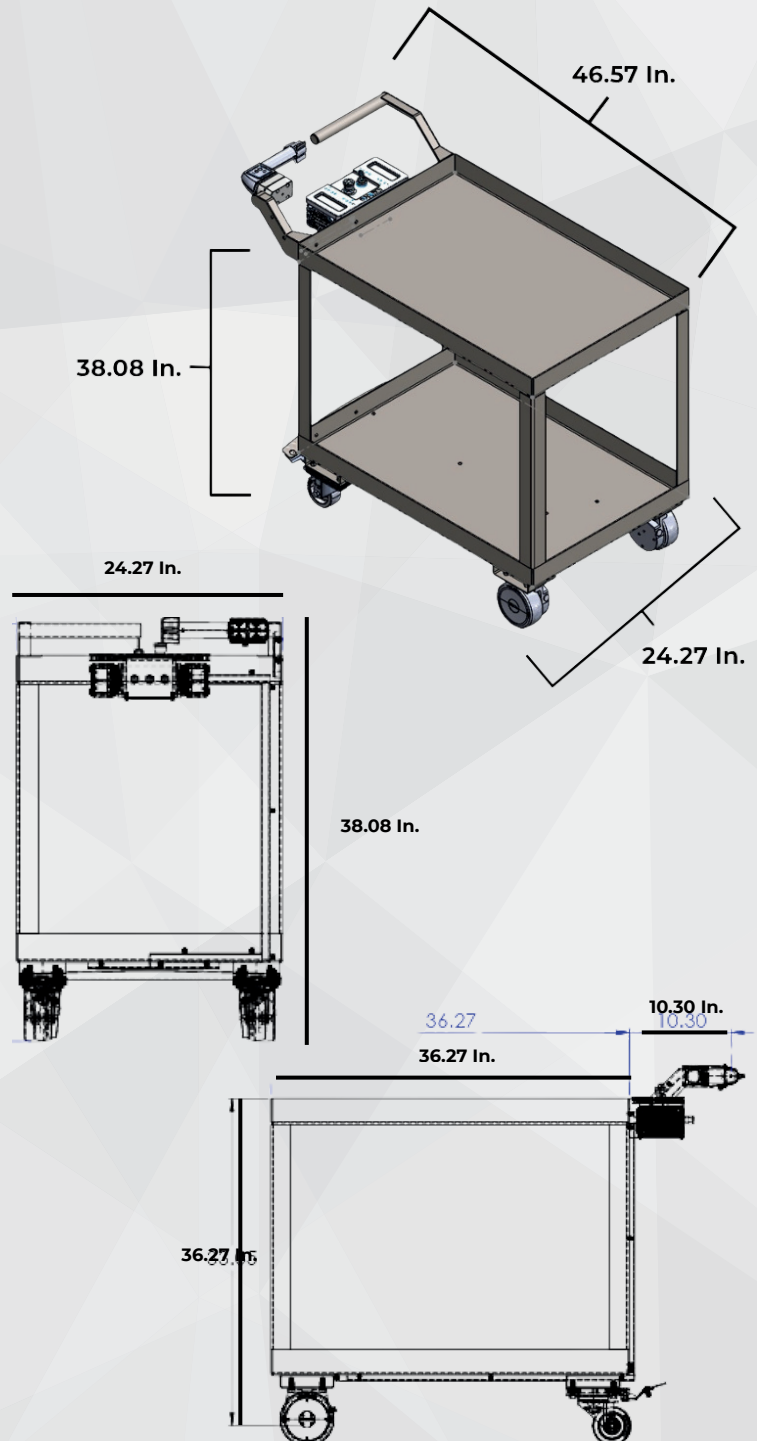

**FOR PRICING, AVAILABILITY, AND ERGONOMIC SOLUTIONS, CONTACT BARRON EQUIPMENT.**

(800)397-6690 • 4710 N Brady St • Davenport, IA 52806 • [www.barroneq.com](http://www.barroneq.com)