

Project: _____

Item: _____

Quantity: _____

Low Boy Stock Cart



1184



1183

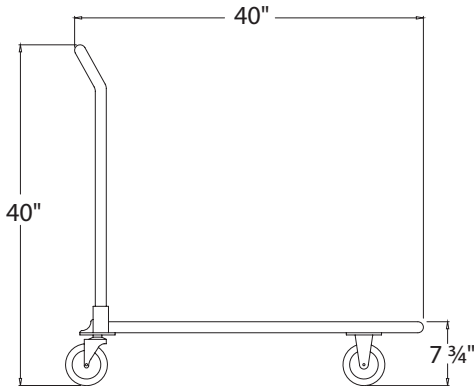
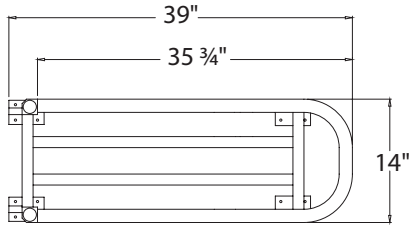

1184

Designed for transporting heavy loads from the back room to the sales floor, this cart easily maneuvers through narrow aisles and tight corners

Rounded front helps protect walls and displays.

- Framework is constructed of 1½" x 1½" x .070" wall tubing.
- Handle is constructed of 1½" diameter pipe.
- Model 1183: Equipped with six plate type casters; four 5" swivel, two 6" x 2" rigid.
- Model 1184: Equipped with four 5" plate type casters; two swivel, two rigid.
- Five-Year Guarantee against material defects and workmanship.
- Lifetime Guarantee against rust and corrosion.
- NSF Certified.

► Low Boy Stock Cart

Model No.	Size W-H-L	Weight Capacity	Deck Height	Number Of Casters	Ship Lbs.
1183	16" x 41" x 54"	1000 lbs.	9½"	6	40.5
1184	14" x 40" x 39"	1000 lbs.	7¾"	4	23

Model #1183: four 5" swivel, two 6" rigid plate type casters.

Model #1184: two 5" swivel, two rigid plate type casters.

Each Unit Has A Removable Handle.

