

Project: \_\_\_\_\_

Item: \_\_\_\_\_

Quantity: \_\_\_\_\_

## Threshold Ramp



Ease your next big delivery with the assistance of this Threshold Ramp. Able to support up to 750 pounds of weight, this heavy-duty ramp can provide a solid transition point for whatever you need to move. Use this loading ramp to smoothly navigate over a curb. The textured, nonslip surface allows for safe usage even in wet weather. Raised side safety rails ensure that the wheels of a moving cart won't slide off the edges during operation, and the integrated handle make this lightweight ramp easy to reposition and transport.



- Tool-free installation for the ease of use
- Lightweight all aluminum will not rust!  
- 5052-H32 Alloy, 3/16" thick.
- 750 lbs. Load Capacity...Weighs only 16 lbs.
- Anti-slip traction tape strip for secure footing.
- 2" x 5" hand cut-out for carrying or hanging in delivery truck.
- 1 1/2" high safety side rail.
- Flat transition top and angle stops underneath keep ramp secure against curb when in use.  
- 2" to 7" service height.
- One-Year Guarantee against material defects and workmanship.
- Lifetime Guarantee against rust and corrosion.

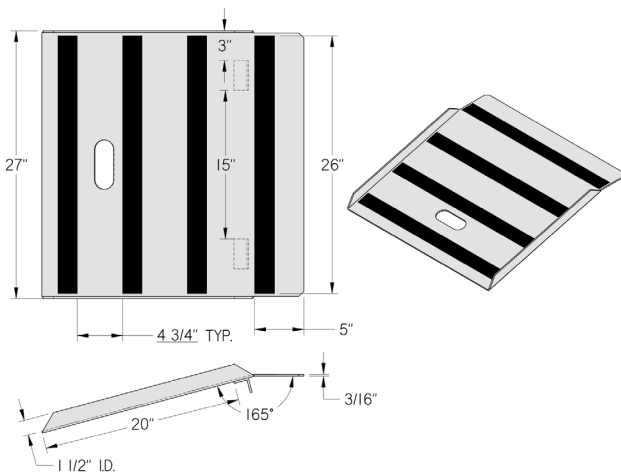

### ► Curb / Threshold Ramp

Model No.	Size W-H-L	Weight Capacity	Net Lbs.	Ship Lbs.
50172	27" x 27" O.D. 26 1/2" x 27" I.D.	750 lbs.	17	16

Fitted with anti-slip traction tape for secure footing.



Barron Equipment and Overhead Doors || [Barroneq.com](http://Barroneq.com) || Made in the USA

4710 N Brady St • Davenport, IA 52806 || Phone: (800) 397-6690 Davenport • (877) 262-6021 Des Moines || Fax: (563) 391-1321

This information is for general sales and engineering use only. Barron Equipment reserves the right to modify or make changes at any time, without notice, to materials and specifications.