

MODEL 351/352

HEAVY DUTY FREESTANDING JIB CRANE

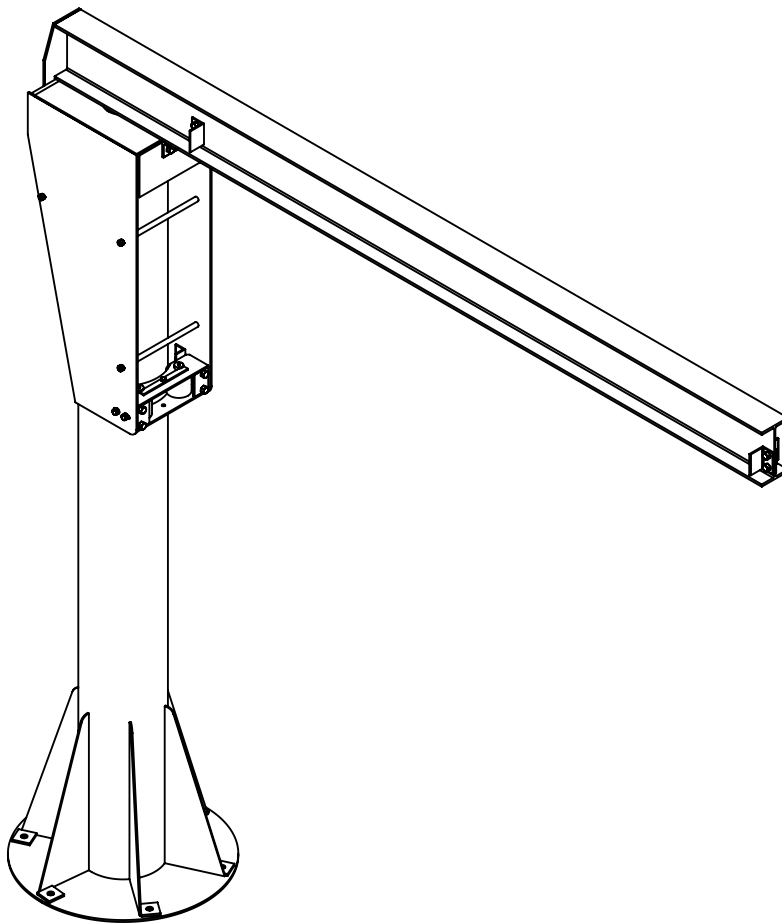

SERIAL #:

WARNING

This equipment should not be installed, operated or maintained by any person who has not read and understood all the contents of this manual. Failure to read and comply with the contents of this manual can result in serious bodily injury or death, and/or property damage.

Table of Contents

<u>Section</u>	<u>Page Number</u>
Important Information and Warnings.....	3
Technical Information and Specifications.....	4
Crane Terms.....	5
Pre-Installation and Installation.....	6
Head and Boom Installation.....	9
Torque Specifications.....	10
Rotation Stops (If Applicable).....	11
Tight Wire Kit (If Applicable).....	12
Operation Introduction.....	13
Shall's and Shall Not's for Operation.....	14
Maintenance Inspection.....	15
Lubrication.....	16
Troubleshooting.....	17
Warranty.....	18
Parts Information.....	19
Jib Crane Parts Breakdown.....	20
Roller Cage Parts Breakdown.....	22

Important Information and Warnings

WARNING

ONLY COMPETENT ERECTION PERSONNEL FAMILIAR WITH STANDARD FABRICATION PRACTICES SHOULD BE EMPLOYED TO ASSEMBLE HANDLING SYSTEMS CRANES BECAUSE OF NECESSITY IN INTERPRETING THESE INSTRUCTIONS. HANDLING SYSTEMS IS NOT RESPONSIBLE FOR QUALITY OF WORKMANSHIP PERFORMED DURING CRANE INSTALLATION.

WARNING

ALL HANDLING SYSTEMS EQUIPMENT IS NOT DESIGNED FOR OR MADE FOR TRANSPORTING HUMANS. FAILURE TO COMPLY WITH ANY ONE OF THE LIMITATIONS STATED IN THIS CRANE MANUAL CAN RESULT IN PROPERTY DAMAGE, INJURY, OR DEATH. PLEASE TAKE ALL NECESSARY PRECAUTIONS DURING INSTALLATION.

WARNING

CONSULT WITH A QUALIFIED STRUCTURAL ENGINEER TO DETERMINE IF YOUR SUPPORT STRUCTURE IS ADEQUATE TO SUPPORT THE LOADS GENERATED BY ANCHOR BOLT FORCE, OVERTURNING MOMENT, OR AXIAL LOAD OF YOUR CRANE.

WARNING

CRANE CANNOT BE UTILIZED AS A GROUND: A SEPARATE GROUND WIRE IS REQUIRED.

WARNING

DO NOT MODIFY CRANE IN ANY WAY. ANY ALTERATIONS DONE IN THE FIELD WITHOUT CONSENT FROM HANDLING SYSTEMS WILL VOID ALL WARRANTY.

WARNING

OVERLOADING AND IMPROPER USE CAN RESULT IN INJURY

WARNING

- MANUAL MUST BE FULLY READ AND UNDERSTOOD BY QUALIFIED ERECTION PERSONNEL PRIOR TO INSTALLATION AND USE OF PRODUCT.
- CRANE IS NOT DESIGNED FOR AND SHOULD NOT BE USED FOR LIFTING OR TRANSPORTING HUMANS
- CRANE CAN NOT BE UTILIZED AS A GROUND.
- DO NOT FIELD MODIFY CRANE IN ANY WAY
- CONSULT WITH QUALIFIED STRUCTURAL ENGINEER TO DETERMINE IF JIB CRANE SUPPORT STRUCTURE IS ADEQUATE BASED ON THE LOADS GENERATED BY THE JIB CRANE



Technical Information and Specifications

Product Code for Pillar Base Mounted Jib Crane

351 - 1000 - 08 - 10

Type of Free Standng Jib Crane:

351 = Heavy duty (Base Plate Mounted)
352F = Heavy Duty (Foundation Mounted)
352S = Heavy Duty (Sleeve Mounted)

Capacity Code (examples):

1000 = 1,000lbs (1/2 US Ton)
4000 = 4,000lbs (2 US Ton)
10000 = 10,000lbs (5 US Ton)

Span (examples):

08 = 8ft
10 = 10ft
14 = 14ft

Underboom Height (examples):

10 = 10ft
14 = 14ft

Operating Conditions and Environment

Temperature range: -30°F to +150°F (-34°C to 66°C)

Relative Humidity: 85% or less

Crane Terms

In order to better understand jib cranes, here are the commonly used terms that are used to specify and design jibs.

- **Anchor Bolts:** Large steel bolts used to mount a base mounted pillar jib crane to the H.S.I. recommended foundation.
- **Boom:** The horizontal beam on which the hoist trolley travels.
- **Fitting Centers:** The distance, centerline to centerline, between two support brackets (fittings) of a wall mounted jib crane.
- **Capacity:** The maximum live weight that the crane is designed to support.
- **End Stops:** Bolted to each end of the boom to prevent the trolley from falling off of the beam.
- **Foundation:** For free standing pillar base mounted jibs. Foundations are used to support the jib and prevent it from tipping over.
- **Gussets:** Reinforcing plates used to stiffen mast at the base plate.
- **Head:** Houses the roller, and lowers the crushing forces that are imposed on the mast.
- **Height Under the Boom (H.U.B.):** The distance from the finished floor to the underside of the crane boom. To find the under-boom, take the height of the load, plus the distance the load is lifted, plus the headroom requirements of the hoist/trolley and any attachments. Extra room aside from mandatory room needed could be helpful.
- **Mast:** The vertical member of the jib, which supports the crane. Pillar jibs have round pipes as masts.
- **Overall Height:** The highest point of the jib crane (including any hardware). A minimum clearance (usually 3") is required from any overhead obstruction.
- **Hoist:** The actual lifting mechanism (powered by electric, air, or manual movement) that hangs from the trolley that rides on the boom of a jib crane.
- **Trolley:** The mechanism that travels back and forth on the crane boom (powered by electric, air, or manual movement) which the hoist hangs from.
- **Overtipping Moment:** The overturning moment is the force applied to the mounting structure of a self-supporting pillar jib. This load is created by suspending a load from the boom, and is greatest at full load, at the very end of the boom.
- **Rotation Stops:** Limits the rotation of a pillar base mounted jib crane boom (which are standard at 360°). Stops are field welded to the mast.
- **Span:** The span for a pillar base mounted jib crane is the distance from the center of the mast to the end of the boom. The span for a column mounted crane is measured from the face of the mounting surface to the end of the boom. The span for a mast type jib crane is measured from the center of the vertical mast to the end of the boom.
- **Thrust and Pull:** Thrust and Pull are forces applied to a wall/column mounted jib cranes support structure. Thrust is the pushing force exerted on the structure, and pull is the tensile, or pulling force. Thrust and Pull are equal to each other (but opposite in direction), and are given for maximum at full load at the end of the boom.
- **Clear Span:** The measurement between the end stops on a crane boom.
- **Hook Travel:** The distance that the hook on the hoist travels.

Pre-Installation

1. Check jib crane for physical damage due to shipping.
2. Ensure all capacity stickers and warning labels are clearly visible and properly affixed.
3. Check packing list to ensure no parts have been lost prior to initiating assembly of crane
4. See Foundation Drawing and Jib Crane Drawing for bolt locations and dimensions.
5. Read entire manual before installing the crane.
6. Identify crane model (351, 352F, 352S) - See **Figure 1**, **Figure 2**, and **Figure 3**. Find the applicable assembly instructions below based on your jib crane model type.

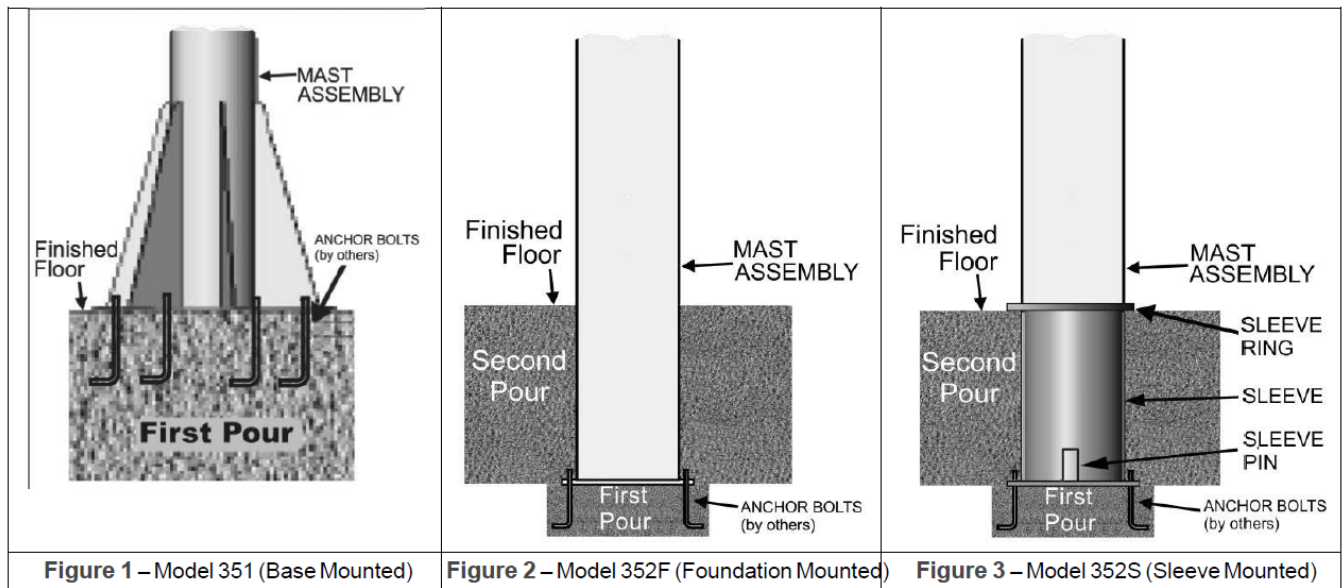

Installation

1. If multiple cranes were ordered, locate stamped serial number on each crane part for proper part matching during installation. Although crane parts may appear to be identical, each crane is assembled and built separately. All parts that do not have the same stamped serial number may not line up properly for installation.
2. Consult a qualified structural engineer to determine that your support structure is adequate to support the loads generated by anchor bolt force, overturning moment, or axial load of your crane. Suggested foundation requirements and curing times are recommendations only. Because conditions may vary, consult a qualified professional to verify foundation requirements.
3. Recommended jib crane foundation requirements are based on a soil pressure of 2500 lbs. per square foot. Recommended concrete for jib crane foundation is 3000 lbs. per square inch of compressive force.
4. Recommended curing time for foundation/concrete before mast installation is 10 days. Recommended curing time for foundation/concrete before loading crane to full capacity is 28 days.

Model 351: Heavy Duty – Base Mounted (See Figure 1):

1. Reference Foundation Drawing and Jib Crane Drawing included in the jib crane information packet.
2. Pour foundation with ANCHOR BOLTS located according to BASE PLATE bolt pattern. Ensure the proper length of ANCHOR BOLT is exposed above floor level (see Foundation Drawing).
3. After foundation is properly cured, spread grout over foundation approximately 1" thick & same diameter as BASE PLATE (see Foundation Drawing). Grout must be a non-shrink, high compressive machinery type grout.
4. Lower MAST ASSEMBLY over ANCHOR BOLTS and set on foundation grout surface (see **Figure 1**). Tighten ANCHOR BOLTS until mast is plumb in all directions (see **Figure 6**). Grout is soft and will allow BASE PLATE to settle for plumbing procedure. Plumbing of mast assembly is very important and will affect performance of jib crane.
5. After grout has properly cured, fully tighten ANCHOR BOLTS to manufacturer's specification. Verify that the MAST ASSEMBLY is still plumb.
6. Locate THRUST BEARING, lubricate with high grade grease and set on BEARING PIN at the top of the MAST ASSEMBLY (see **Figure 7**).
7. Proceed to **Page 9** to install the HEAD and BOOM ASSEMBLY.

Model 352F: Heavy Duty – Foundation Mounted (See Figure 2):

1. Reference Foundation Drawing and Jib Crane Drawing included in the jib crane information packet.
2. Excavate proper sized area to prepare for crane foundation (see Foundation Drawing).
3. First Pour – Refer to Foundation Drawing for anchor bolt location to set ANCHOR BOLTS in first pour.
4. After concrete has hardened and ANCHOR BOLTS are set, spread mechanical grout over mounting area approximately 1-1/4" thick. Grout must be a non-shrink, high compressive machinery type grout.
5. Lower MAST ASSEMBLY over ANCHOR BOLTS and set on foundation grout surface. Tighten ANCHOR BOLTS until mast is plumb in all directions (see **Figure 6**). Grout is soft and will allow for proper plumbing of MAST ASSEMBLY. Plumbing of mast assembly is very important and will affect performance of jib crane.
6. After grout has properly cured, fully tighten ANCHOR BOLTS to manufacturer's specifications so that MAST ASSEMBLY does not move during second pour. Verify MAST ASSEMBLY is still plumb.
7. Second Pour - After MAST ASSEMBLY is set and grout has dried, reference Foundation Drawing and proceed with second pour using reinforcing rods as shown on the Foundation Drawing.
8. After concrete has properly cured, locate THRUST BEARING, lubricate with high grade grease and set on BEARING PIN at the top of the MAST ASSEMBLY (see **Figure 3-7**).
9. Proceed to **Page 9** to install the HEAD and BOOM ASSEMBLY.

Model 352S: Heavy Duty – Sleeve Mounted (See Figure 3):

1. Reference Foundation Drawing and Jib Crane Drawing included in the jib crane information packet.
2. Excavate proper sized area to prepare for crane foundation (see Foundation Drawing).
3. First Pour – Refer to Foundation Drawing for location to set ANCHOR BOLTS in first pour.
4. After concrete has hardened and ANCHOR BOLTS are set, spread mechanical grout over mounting area approximately 1-1/4" thick. Grout must be a non-shrink, high compressive machinery type grout. Plumbing of sleeve is very important and will affect performance of jib crane.
5. Install SLEEVE and tighten bolts making sure the SLEEVE is plumb in all directions (see **Figure 6**). Grout is soft and will allow for proper plumbing of SLEEVE.
6. After grout has properly cured, fully tighten ANCHOR BOLTS to manufacturer's specifications so that SLEEVE does not move during second pour. Verify SLEEVE is still plumb.
7. Second Pour - Reference Foundation Drawing and proceed with second pour using reinforcing rods as shown on Foundation Drawing. Make sure SLEEVE RING is resting on top of poured foundation (see **Figure 3**)

After Concrete has Properly Cured:

8. Insert MAST into SLEEVE and allow the bottom hole of MAST to slide over SLEEVE PIN (see **Figure 3**) Plumbing of mast assembly is very important and will affect performance of jib crane.
9. Plumb MAST ASSEMBLY in all directions (see **Figure 6**). Make sure MAST ASSEMBLY remains plumb throughout **step 9**.
10. Place SPLIT RINGS provided around bottom part of MAST resting on top of SLEEVE RING (see **Figure 5**). Tack weld SPLIT RING into position to MAST and SLEEVE RING. After SPLIT RING is tack welded into proper position check once more that mast has remained plumb then weld SPLIT RING all around MAST and weld SPLIT RING completely around to SLEEVE RING. Verify MAST is still plumb.
11. Locate THRUST BEARING, lubricate with high grade grease and set on BEARING PIN at the top of the MAST (see **Figure 7**).

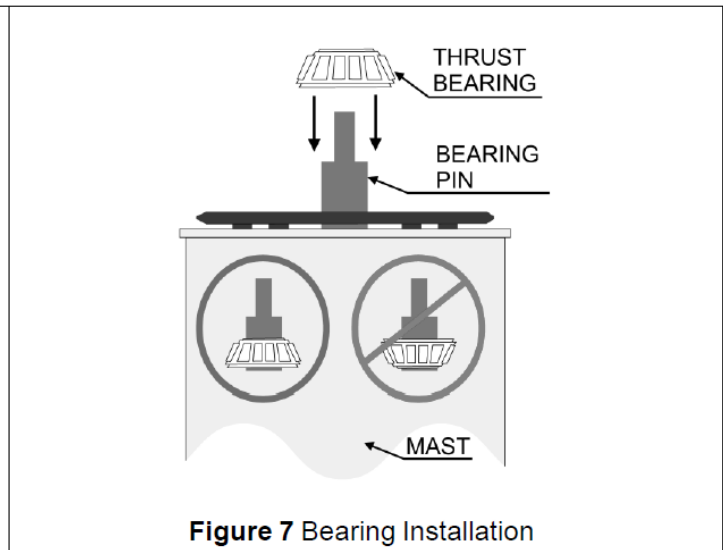
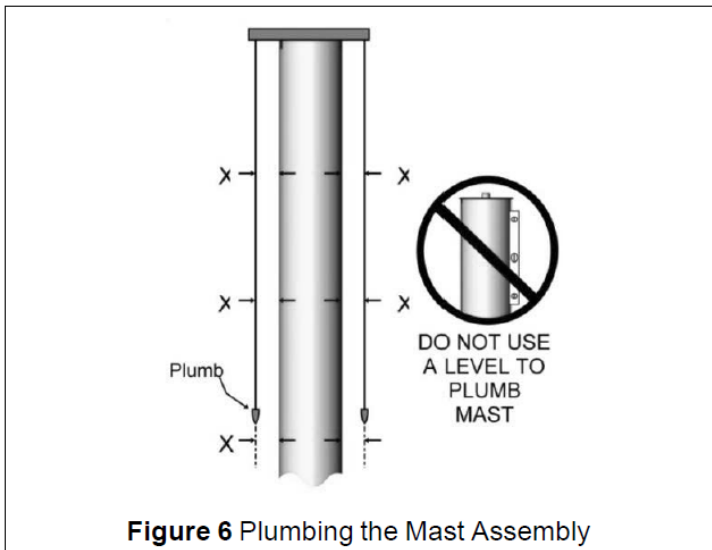
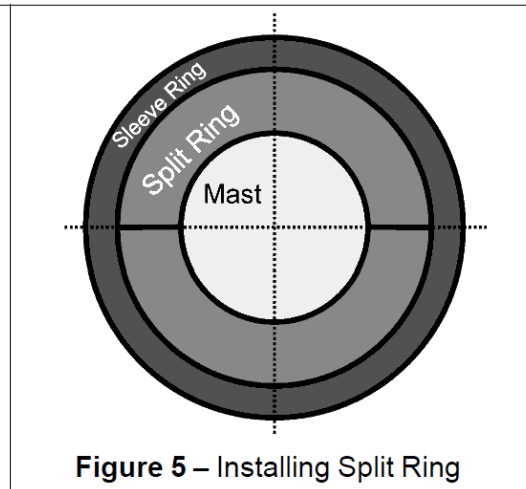
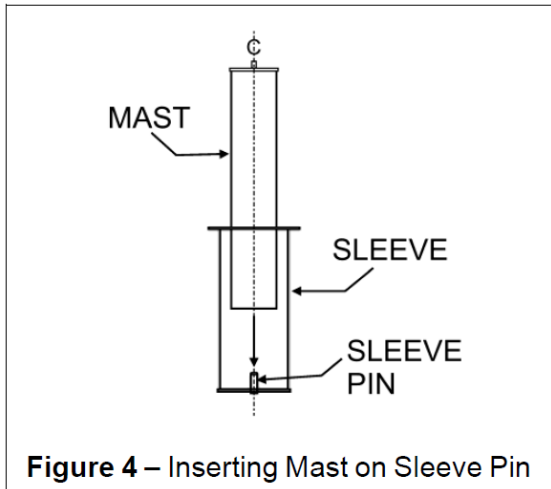

Head and Boom Installation

1. Reference **Figure 8** for general assembly layout. Reference Jib Crane Drawing for bolt sizes and locations.
2. Depending on size of crane and machinery available for installation, the BOOM ASSEMBLY and HEAD ASSEMBLY can be pre-assembled for mounting to MAST ASSEMBLY. Use the following procedure if this is the desirable installation method (if an alternative method is preferred, continue to **Step 7**).
3. Bolt the BOOM ASSEMBLY to HEAD ASSEMBLY at BOOM BACK PLATE and FRONT SUPPORT with bolts provided.
4. Remove SPACER RODS if necessary.
5. Lift entire assembly (BOOM and HEAD) over top of the MAST and make sure BEARING HOUSING is properly seated on THRUST BEARING.
6. Replace SPACER RODS if removed (continue to **Step 12**).
7. Installation of HEAD ASSEMBLY and BOOM ASSEMBLY in separate pieces:
8. Place HEAD ASSEMBLY on MAST ASSEMBLY with the top plate of HEAD ASSEMBLY resting on top plate of MAST ASSEMBLY. Be sure that the THRUST BEARING is centered in HEAD ASSEMBLY's top plate cut-out. Remove SPACER RODS if necessary.
9. Set BOOM ASSEMBLY on top of THRUST BEARING making sure BEARING HOUSING is lined up with THRUST BEARING.
10. Fasten BOOM ASSEMBLY to HEAD ASSEMBLY using bolts provided at BOOM BACK PLATE and FRONT SUPPORTS. See torque specs on **Page 10**.
11. Replace spacer rods if removed (continue to **Step 12**).
12. Lubricate rollers in ROLLER CAGE ASSEMBLY with high grade grease.
13. Under no load condition, adjust the BOOM ASSEMBLY so that the far end of the boom is span(in.)/300 above the horizontal. To adjust desired BOOM ASSEMBLY elevation loosen the four side bolts on the side plates that hold the roller cage in place then tighten TENSION BOLTS on ROLLER CAGE ASSEMBLY while moving the tip of BOOM ASSEMBLY up or down. Ensure rollers are making full contact with MAST ASSEMBLY. If additional adjustment to tip of boom is needed a steel shim (max 1/4" thick) should be inserted UNDER the boom flange at the front of the boom to head assembly connection. After shim is placed adjust tip of boom elevation with method described above. (min. shim width/length: length of boom flange x 2 inches in width x 1/4" thick maximum)
14. Rotate BOOM ASSEMBLY slowly and check around 360° degrees for binds or slow down spots. Remove interference if any.
15. Check all bolt connections including ANCHOR BOLTS and tighten if necessary.
16. If applicable, install MECHANICAL ROTATION STOPS – See **Page 11**.
17. Bolt two inner TROLLEY STOPS to BOOM ASSEMBLY. Slide Hoist/Trolley onto BOOM ASSEMBLY, then bolt two remaining TROLLEY STOPS to BOOM ASSEMBLY. (For units with Tight Wire Kit, refer to **Page 12**).
18. The unit should be ready for operation. Please call Product Support with any questions during install.

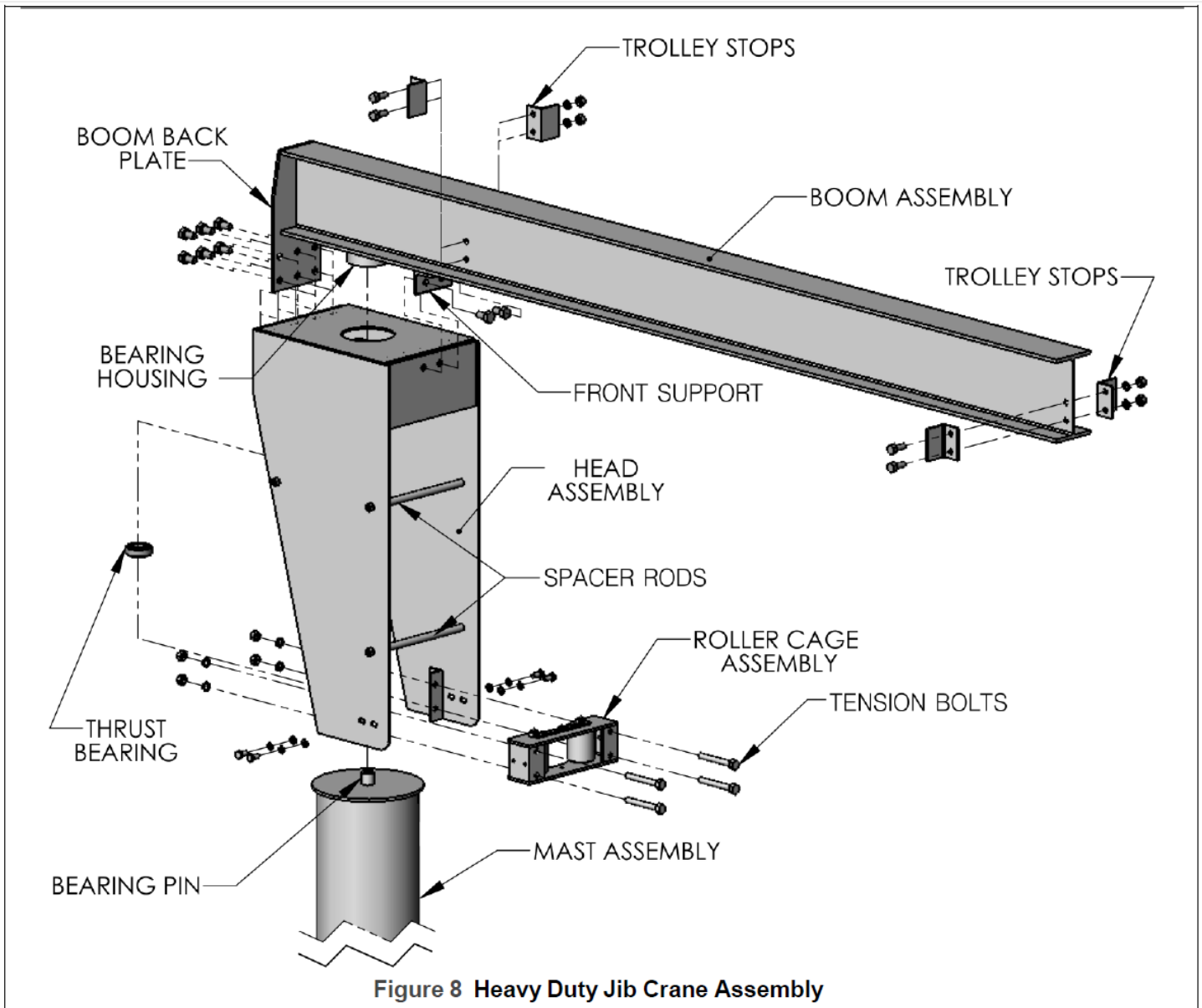
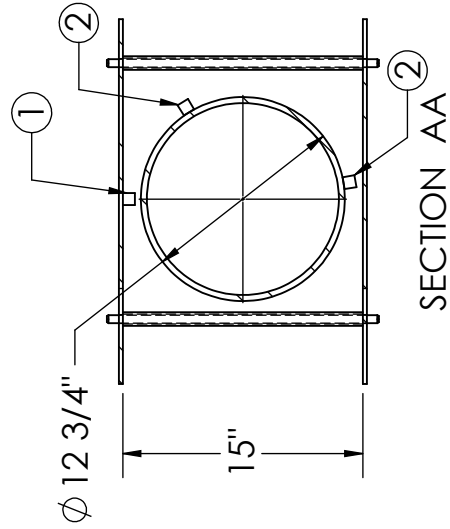
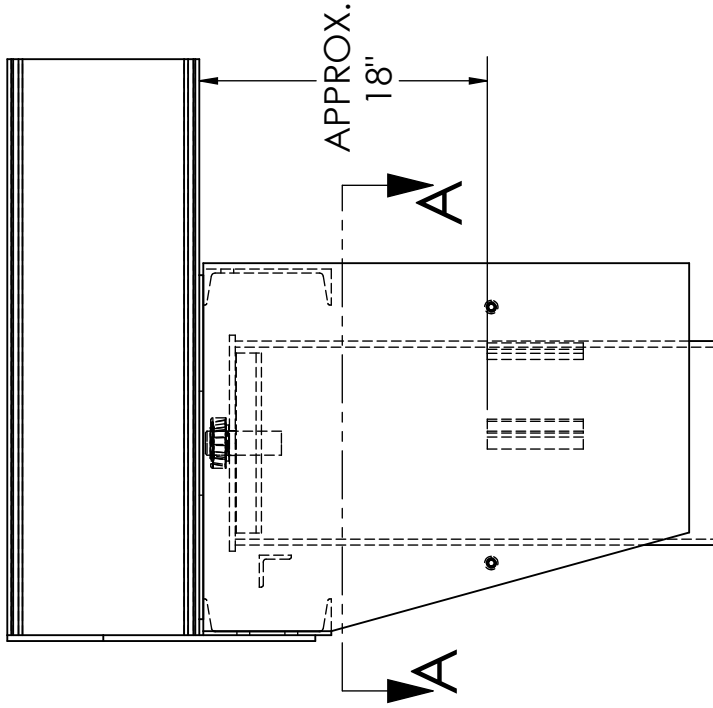

Figure 8 Heavy Duty Jib Crane Assembly

Chart 1-L

Torque Specifications	
BOLT DIA.	TORQUE
1/4" - 20	6 ft.-lbs.
3/8" - 16	20 ft.-lbs.
1/2" - 13	50 ft.-lbs.
5/8" - 11	95 ft.-lbs.
3/4" - 10	175 ft.-lbs.
7/8" - 9	300 ft.-lbs.

9994500



NOTES:

1. MECHANICAL ROTATION STOPS WILL PERMIT 359° OF ROTATION.
2. ITEM 1 WELDED TO HEAD AT LOCATION SHOWN BY MANUFACTURER.
3. ITEM 2 SHIPPED LOOSE TO BE LOCATED & WELDED TO PIPE MAST ASSEMBLY IN FIELD AT DESIRED POSITION.
4. WHEN ERECTING CRANE, NOTE RELATIONSHIP OF BAR STOP INSIDE HEAD TO BAR ON MAST ASSEMBLY FOR PROPER ORIENTATION OF STOP.

ITEM NO.	PART NUMBER	DESCRIPTION	QTY
1	9164500	3/4" SQUARE BAR 6" L	1
2	9164500	3/4" SQUARE BAR 6" L	2

HANDLING SYSTEMS INTERNATIONAL
LAGRANGE, IL 60525

DESCRIPTION: MECHANICAL ROTATION STOPS (12 3/4" DIA PIPE)
 PART NUMBER: 9994500 MATERIAL:

DRAWN BY: D. Grujic DATE DRAWN: 11/14/07 DRAWING SIZE: A SHEET NUMBER: 1 SCALE: 1:12

PROPRIETARY AND CONFIDENTIAL: THE INFORMATION CONTAINED IN THIS DRAWING IS THE SOLE PROPERTY OF HANDLING SYSTEMS INTERNATIONAL, INC. ANY REPRODUCTION IN PART OR AS A WHOLE WITHOUT THE WRITTEN PERMISSION OF HANDLING SYSTEMS INTERNATIONAL, INC. IS PROHIBITED.

TOLERANCES: ANGLES +/30 MINUTES - ALL DIMENSIONS ARE IN INCHES UNLESS OTHERWISE SPECIFIED.

9990000

A

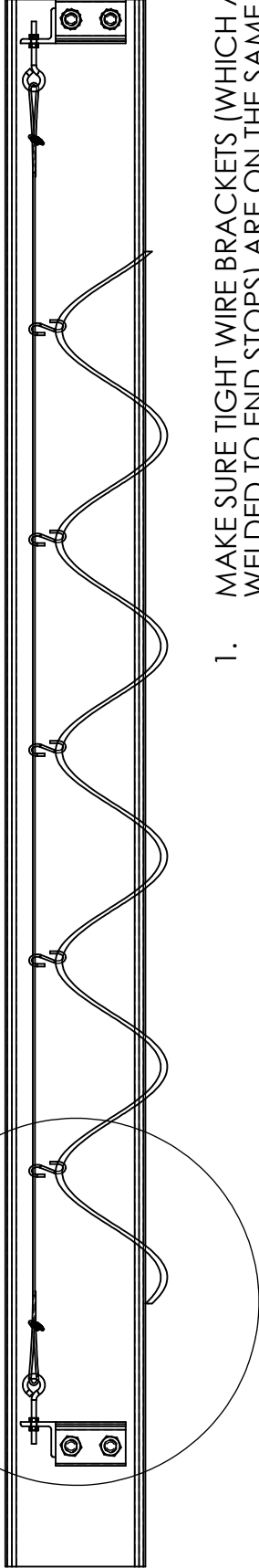

1. MAKE SURE TIGHT WIRE BRACKETS (WHICH ARE WELDED TO END STOPS) ARE ON THE SAME SIDE OF BOOM.
2. LOOP CABLE THROUGH EYE BOLT AT ONE END. TIGHTEN WITH CABLE CLAMP. PUT "S" HOOKS ON CABLE. LOOP CABLE THROUGH OTHER EYE BOLT. TIGHTEN WITH CABLE CLAMP.
3. SLIP EYE BOLT THROUGH TIGHT WIRE BRACKET AND TIGHTEN EYE BOLT UNTIL TIGHT WIRE IS TIGHT.
4. ****NOTE: FOR CRANES WITH 6" BEAM TIGHT WIRE BRACKET MAY HAVE DIFFERENT ORIENTATION DUE TO SPACE CONSTRAINTS.**

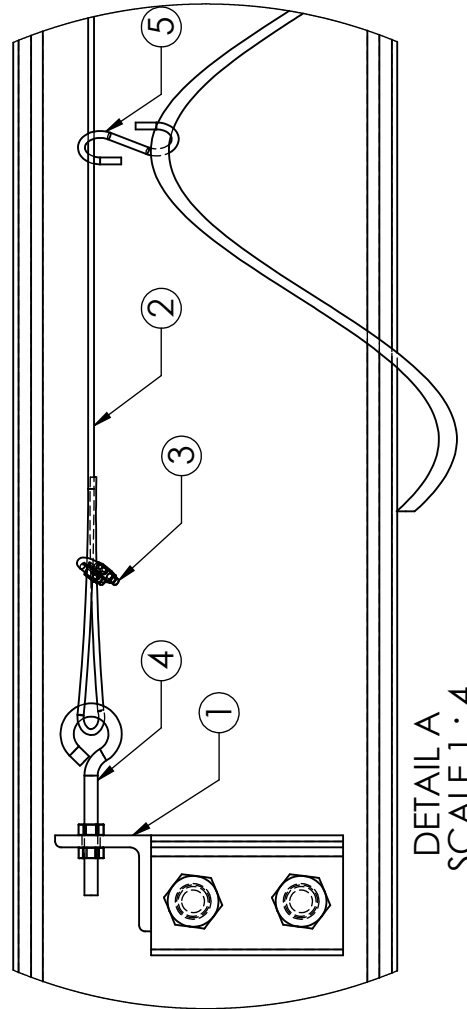
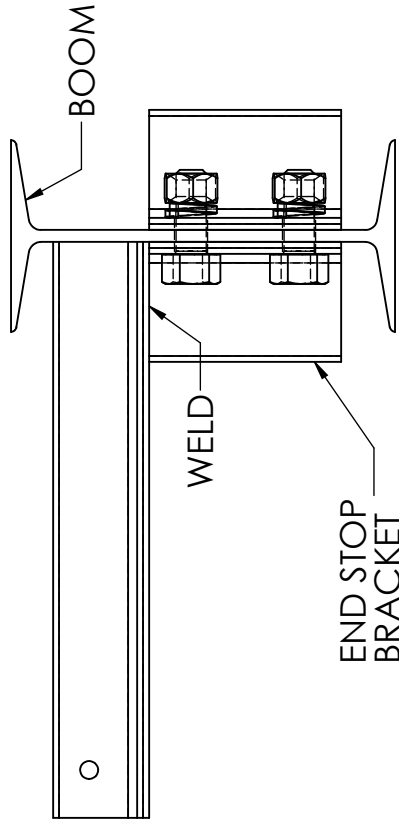

DETAIL A
SCALE 1 : 4

ITEM NO.	DESCRIPTION	QTY.
1	TIGHT WIRE ANGLES (WELDED TO ES)	2
2	1/8" DIA CABLE (LENGTH = CRANE SPAN)	1
3	CABLE CLAMPS	2
4	5/16" EYE BOLTS W/ NUTS	2
5	"S" HOOKS	#

HANDLING SYSTEMS INTERNATIONAL
L.AGRANGE, IL 60525

DESCRIPTION **TIGHT WIRE ASSEMBLY**

PART NUMBER **9990000** MATERIAL

DRAWN BY **D. Grujic** DATE DRAWN **05/02/07** DRAWING SIZE **A** SHEET NUMBER **1** SCALE: **1:10**

TOLERANCES: DECIMALS (UNLESS OTHERWISE SPECIFIED) TWO PLACE (.00) + .015 THREE (.000) + .005 INC. ANY REPRODUCTION IN PART OR AS A WHOLE WITHOUT THE WRITTEN PERMISSION OF HANDLING SYSTEMS INTERNATIONAL, INC. IS PROHIBITED. ANGLES +/- 30 MINUTES. ALL DIMENSIONS ARE IN INCHES UNLESS OTHERWISE SPECIFIED.

Operation Introduction

The suggestions below are not intended to take precedence over existing plant safety rules and regulations or OSHA regulations. It is the responsibility of the owner to make personnel aware of all federal, state and local rules and codes, and to make certain operators are properly trained.

DANGER

DO NOT WALK UNDER A SUSPENDED LOAD
KEEP HANDS CLEAR OF ROTATING PARTS

WARNING

CRANE OPERATORS SHALL BE REQUIRED TO READ THE OPERATION SECTION OF THIS MANUAL, THE WARNINGS CONTAINED IN THIS MANUAL, INSTRUCTION AND WARNING LABELS ON THE HOIST OR LIFTING SYSTEM, APPLICABLE ANSI AND OSHA SAFETY STANDARDS, AND THE CRANE OPERATOR'S MANUAL PUBLISHED BY THE CRANE MANUFACTURER'S ASSOCIATION OF AMERICA (CMAA). THE OPERATOR SHALL ALSO BE REQUIRED TO BE FAMILIAR WITH THE CRANE AND CRANE CONTROLS BEFORE BEING AUTHORIZED TO OPERATE THE CRANE OR LIFTING SYSTEM.

CRANE OPERATORS SHOULD BE TRAINED IN PROPER RIGGING PROCEDURES FOR THE ATTACHMENT OF LOADS TO THE HOIST HOOK.

CRANE OPERATORS SHOULD BE TRAINED TO BE AWARE OF POTENTIAL MALFUNCTIONS OF THE EQUIPMENT THAT REQUIRE ADJUSTMENT OR REPAIR, AND TO BE INSTRUCTED TO STOP OPERATION IF SUCH MALFUNCTIONS OCCUR, AND TO IMMEDIATELY ADVISE THEIR SUPERVISOR SO CORRECTIVE ACTION CAN BE TAKEN.

CRANE OPERATORS SHOULD HAVE NORMAL DEPTH PERCEPTION, FIELD OF VISION, REACTION TIME, MANUAL DEXTERITY, HEARING, AND COORDINATION.

CRANE OPERATORS SHOULD NOT HAVE A HISTORY OF OR BE PRONE TO SEIZURES, LOSS OF PHYSICAL CONTROL, PHYSICAL DEFECTS, OR EMOTIONAL INSTABILITY THAT COULD RESULT IN ACTIONS OF THE OPERATOR BEING A HAZARD TO THE OPERATOR OR TO OTHERS.

CRANE OPERATORS SHOULD NOT OPERATE A CRANE OR LIFTING SYSTEM WHEN UNDER THE INFLUENCE OF ALCOHOL, DRUGS, OR MEDICATION.

NOTICE

Read OSHA Specification 1910.179 "Overhead and Gantry Cranes," ANSI B30.11, "Monorails and Underhung Cranes," ASMEB30.16, and any other applicable standards.

Read the hoist manufacturer's Operating and Maintenance Instructions.

Read all labels attached to equipment.

Shall's and Shall Not's for Operation

WARNING

Improper operation of a crane can create a potentially hazardous situation which, if not avoided, could result in death or serious injury, and substantial property damage. To avoid such a potentially hazardous situation **THE OPERATOR SHALL:**

- **NOT** operate a damaged, malfunctioning or unusually performing crane.
- **NOT** operate a crane until you have thoroughly read and understood Manufacturer's Operating and Maintenance Instructions or Manuals.
- Be familiar with operating controls, procedures, and warnings.
- **NOT** operate a crane that has been modified without the manufacturer's approval.
- **NOT** lift more than rated load for the crane/hoist/trolley.
- **NOT** use the crane to lift, support, or transport people.
- **NOT** lift loads over people.
- **NOT** operate a crane unless all persons are and remain clear of the supported load.
- **NOT** operate unless load is centered under hoist.
- **NOT** leave load supported by the crane/hoist unattended unless specific precautions have been taken.
- **NOT** allow the crane to be used as an electrical or welding ground.
- **NOT** remove or obscure the warnings on the crane.
- **NOT** operate a crane on which the safety placards or decals are missing or illegible.
- **NOT** operate a crane that has any changes in rolling effort or unusual noises.
- Warn personnel before lifting or moving a load.
- Warn personnel of an approaching load.
- Ensure that end-stops are in place.
- Ensure that all bolts are tight and have lockwashers.
- **NOT** put hands near rotating parts.

WARNING

Improper operation of a crane can create a potentially hazardous situation which, if not avoided, could result in minor or moderate injury, or property damage. To avoid such a potentially hazardous situation **THE OPERATOR SHALL:**

- Maintain a firm footing or be otherwise secured when operating the crane.
- Make sure the load is free to move and will clear all obstructions.
- Avoid swinging the load or hook.
- Inspect the crane regularly, replace damaged or worn parts, and keep appropriate records of maintenance.
- Use the crane manufacturer's recommended parts when repairing the unit.
- Lubricate the roller bearings per crane manufacturer's recommendations.
- **NOT** allow your attention to be diverted from operating the crane.
- **NOT** allow the crane to be subjected to sharp contact with other cranes, structures, or objects through misuse.
- **NOT** adjust or repair the crane unless qualified to perform such adjustments or repairs.
- Ensure that festooning cannot be snagged or pinched.

JIB BOOM OPERATION

- Verify the hook is high enough to clear any obstruction before using the boom of the jib crane.
- Ensure the jib boom is directly over the load before lifting the load.
- Start moving the jib boom slowly and bring it up to speed gradually.
- Reduce the speed of the boom as it approaches the place where it should stop.

TROLLEY OPERATION

- Refer to the trolley's operating instructions.

HOIST OPERATION

- Refer to the hoist's operating instructions.

Maintenance Inspection

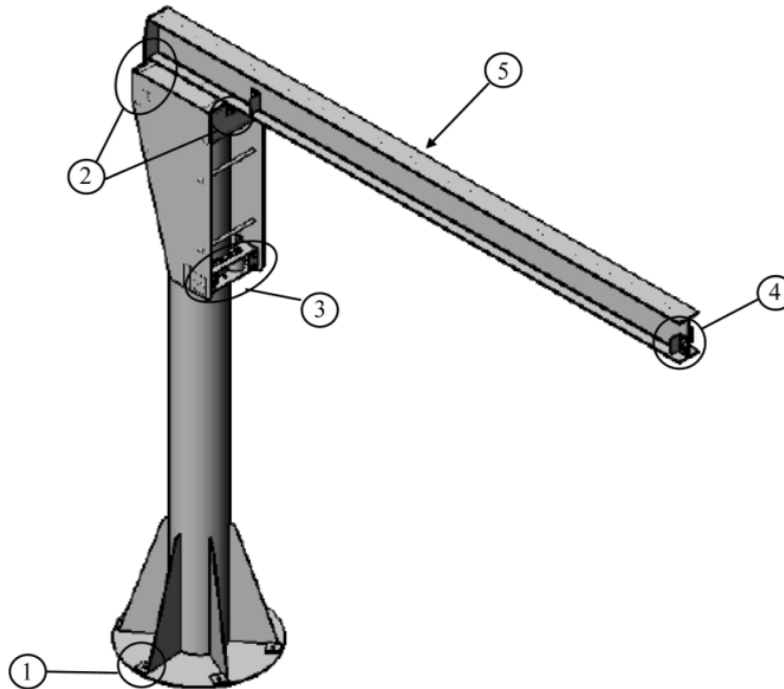

Crane Inspection

Figure No.	Item	Inspection	Frequency
1	Anchor Bolts	Check that the lock-washers are fully compressed and the nuts are tightened to manufacturer's specifications.	Every 500 hours Or 3 months
2	Boom & Head Assembly Hardware	Check that the lock-washers are fully compressed and the nuts are tightened the proper torque specs from chart 1-L (see installation page).	Every 500 hours Or 3 month
3	Thrust Bearings	Make sure both roller bearings are evenly touching the mast, adjust if needed. Grease if needed.	Every 1000 hours Or 6 months
4	End Stop/ Tight Wire Kit	Check that the lock-washers are fully compressed and the nuts are tightened the proper torque specs from chart 1-L (see installation page).	Every 500 hours Or 3 months
5	Leveling Boom Kit	Verify that the end of the boom is at the point of span(in.)/300 above level.	Every 1000 hours Or 6 months
-	Additional Items	Conduct a general inspection of all additional items you may have purchased.	Every 1000 hours Or 6 months
-	General	Conduct a visual inspection of the crane overall and speak with the crane operator about the crane's performance, if any flaws are noticed take crane out of service and report to manufacturer immediately.	Every 1000 hours Or 6 months

WARNING

Any changes in rolling effort or unusual noises must be immediately identified and corrected.

Lubrication

1. The most economical way to maintain a jib crane and keep it in good operating condition is to lubricate all moving parts regularly.
2. Regular inspection of all parts should be made and all loose parts should be adjusted. Parts that become worn should be replaced immediately.
3. The lubrication interval varies with the use of the machine. A crane operating 24 hours a day, 7 days a week, should demand lubrication once a week. Whereas a standard duty crane, operating eight hours a day on a five day week should be lubricated once every two to three weeks. Cranes under a standby classification, being used once or twice a month, should be lubricated at least once every six months.
4. The actual interval from one lubrication to the next depends entirely upon the type and length of operation to which the crane is subjected. These factors are variable and sometimes cannot be definitely determined. In this case, the crane operator or maintenance engineer would determine when the crane should be lubricated.
5. The roller bearings on the jib crane require lubrication. They are serviced by pressure type fittings.
6. The recommended lubricants for these bearings are:
 - a. Texaco Marfax No. 0 for below 32 degrees F
 - b. Texaco Marfax No. 1 for above 32 degrees F
7. If Texaco products are not available, equivalent lubricants are satisfactory.

Troubleshooting

Troubleshooting Guide		
Symptom	Cause	Remedy
Jib crane boom tip will not adjust to span (in.)/300	Bearing housing on boom is not properly seated on the thrust bearing	Properly seat bearing housing on thrust bearing
Jib crane does not rotate smoothly	Rollers are not making flush contact with the mast	Adjust roller cage pitch by loosening the side bolts (do not remove) on the head assembly that hold the cage in position; then tighten or loosen the top and/or bottom tension bolts to adjust the pitch of the rollers
Jib crane does not rotate a complete rotation	Crane boom has an obstruction	Remove any obstruction
	Bearing housing on boom is not properly seated on the thrust bearing	Properly seat bearing housing on thrust bearing



11 Year Warranty

HSI's 11 year warranty is the best in the industry.

What Products Are Covered?

- Manual Rotation Jib Cranes
- Manual Steel Gantry Cranes
- Defects in material and workmanship

The Fine Print:

Handling Systems International, Inc. (known as H.S.I.) warrants manual push/pull Jib and Gantry Crane products it manufactures against defects in material or workmanship for a period of eleven years from date of receipt by purchaser or customer. This warranty does not cover failure or defect in paint or material finish. This warranty does not cover failure or defect caused by operation in excess of recommended rated capacities, misuses, negligence or accident, and alteration or repair of any kind not authorized by H.S.I. H.S.I. systems shall not be modified after manufacture without written authorization of H.S.I. Any field modifications made without written authorization of H.S.I. shall void all H.S.I.'s warranty obligation. H.S.I. agrees to furnish the same or substantially similar replacement part (new or repaired) free of charge, providing the buyer gives immediate written notice of alleged defects, and if requested by H.S.I., returns the defective parts to the factory, for H.S.I.'s inspection and examination. Purchaser or end user shall be solely responsible for all freight and transportation costs incurred in connection with any warranty work provided by H.S.I. hereunder. H.S.I. will not be liable for any loss, injury or damage to persons or property, nor for damages of any kind resulting from failure or defective operation of any materials or equipment furnished hereunder. H.S.I. shall not be liable under any circumstances for any incidental, special and/or consequential damages whatsoever, whether or not foreseeable, including but not limited to damages for lost profits and all such incidental, special and/or consequential damages are hereby also specifically disclaimed. This warranty applies only to H.S.I. equipment or materials which, after our inspection, are determined to be defective either in material supplied or workmanship performed by H.S.I. Where equipment is furnished by H.S.I. but not of its manufacture, H.S.I.'s liability is limited to such adjustment as the actual manufacturer makes to H.S.I. H.S.I. will not be liable for the cost of repairs, alterations, or replacements or any expense connected therewith made or incurred by the purchaser or his agents or employees, except upon written authority from H.S.I. This warranty is personal to purchaser only and applies only to equipment which purchaser has properly operated and maintained in accordance with H.S.I.'s written instructions. H.S.I. assumes no liability for any consequential damages suffered through the use of loss of use of its equipment. This constitutes H.S.I.'s sole warranty with respect to the equipment and material manufactured by itself. H.S.I. makes no other warranty of any kind whatsoever, expressed or implied, and all implied warranties of merchantability and fitness for a particular purpose which exceed the aforementioned obligation are hereby disclaimed by H.S.I.

Parts Information

When ordering Parts, please provide the crane serial number which is stamped into each crane part (see **Figure 9**). The serial number is also located underneath the “HSI” logo.

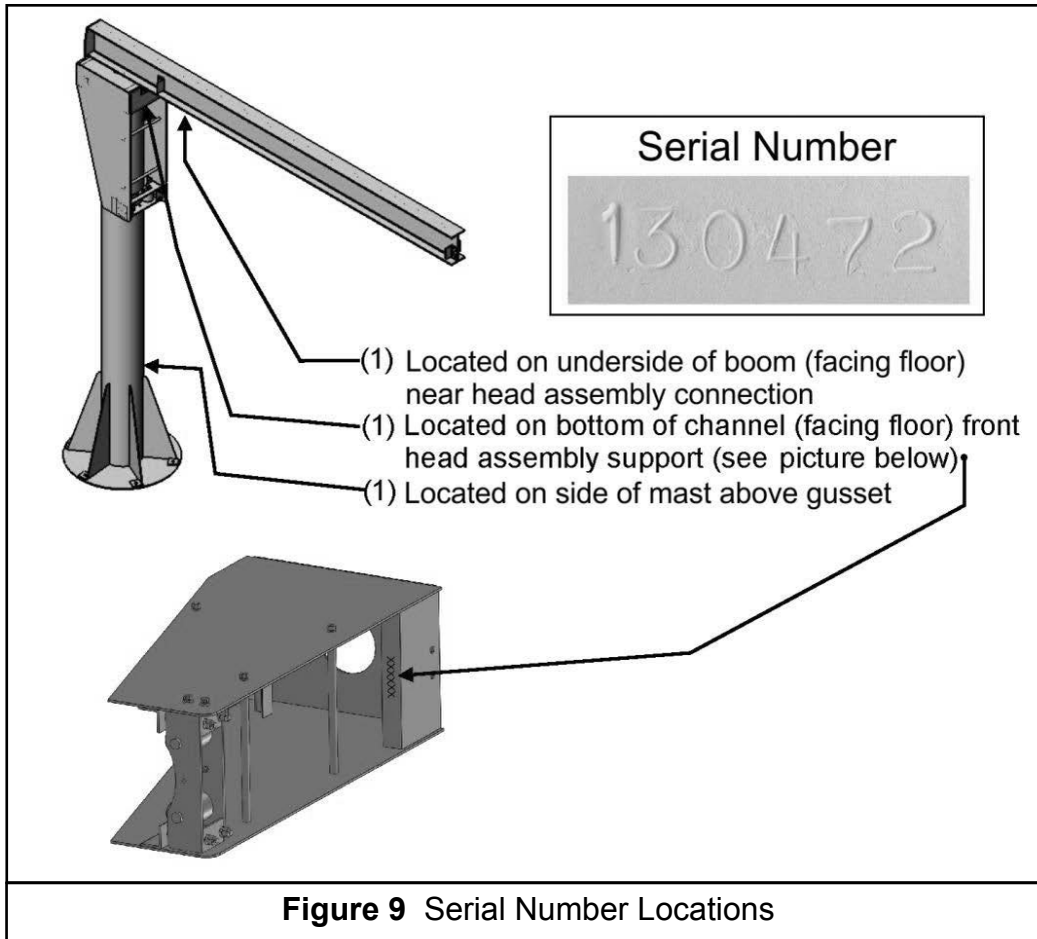

**MAST DIAMETER
M
(INCHES)**

Figure No.	Description	Qty	8-5/8"	10-3/4"	12-3/4"	14"	16"	18"	20"	24"	30"
1A	Top Thrust Bearing	1	HS3381TB				HS6379TB			CALL FACTORY	
1B	Thrust Bearing Cone	1	HS3320CN				HS6320CN			CALL FACTORY	
2	Roller Cage Assembly	1	0110803A	0111003A	0111203A	0111405A	011604A	0111803A	0112003A	0112404A	0113004A
3	Mast Assembly	1	SEE BILL OF MATERIALS								
4	Trolley Stops	4									
5	Boom Assembly	1									
6	Head Assembly	1									
7	Bolt	-									
8	Lock Washer	-									
9	Nut	-									
10	Bolt	-									
11	Lock Washer	-									
12	Nut	-									

Roller Cage Assembly Parts

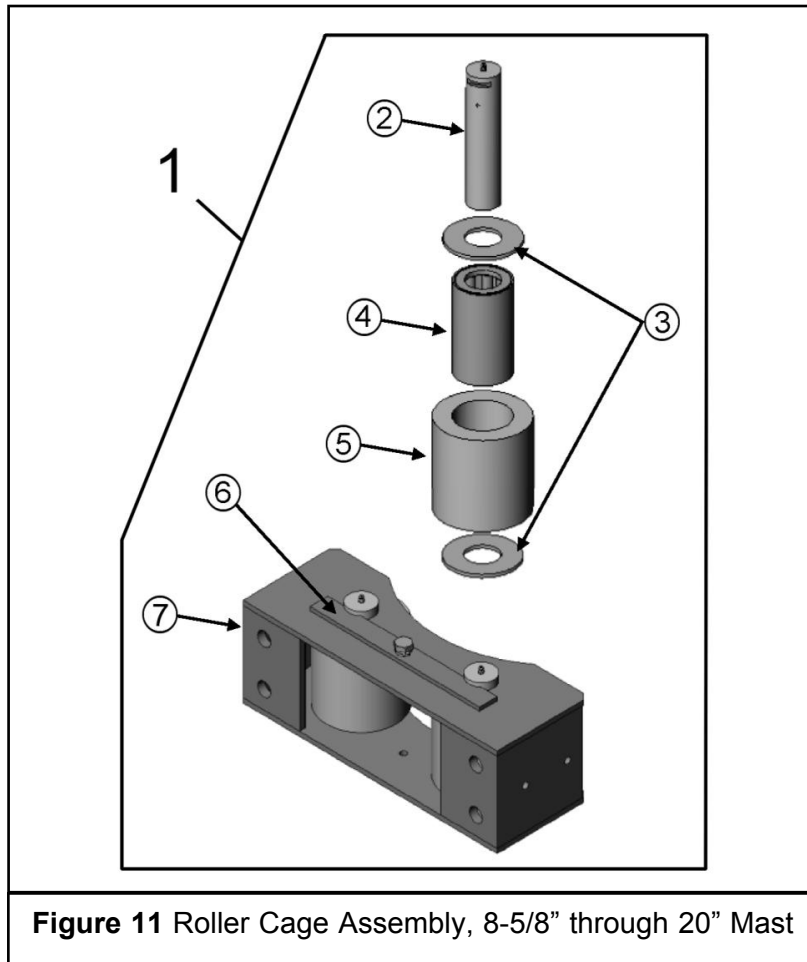

Figure 11 Roller Cage Assembly, 8-5/8" through 20" Mast

Figure No.	Description	Qty	MAST DIAMETER (INCHES)						
			8-5/8"	10-3/4"	12-3/4"	14"	16"	18"	20"
1	Roller Cage Assembly	1	0110803A	0111003A	0111203A	0111405A	0111604A	0111803A	0112003A
2	Roller Pin with Zirk Fitting	2	0191201			0191402	0191603		
3	Flat Spacer Washer	4	097112501			097143801	097175001		
4	Roller Bearing	2	0700664			0700964	0700980		
5	Roller	2	0181201			0181402	0181603		
6	Keeper Bar	1	2190801	2251201		2254101	2251601	2251801	2252001
7	Roller Cage Weldment	1	0110803	0111003	0111203	0111405	0111604	0111803	0112003

Roller Cage Assembly Parts

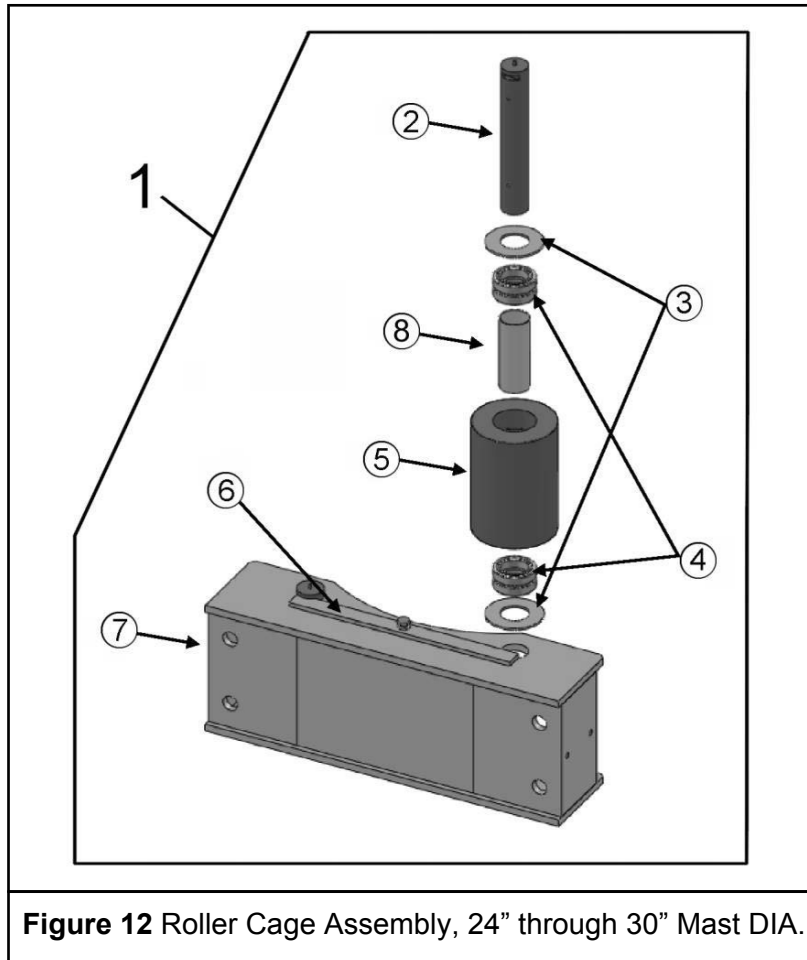

Figure No.	Description	Qty	MAST DIAMETER	
			24"	30"
1	Roller Cage Assembly	1	0112404A	0113004A
2	Roller Pin with Zirk Fitting	2	192404	0193005
3	Flat Spacer Washer	4	97200001	097225001
4	Roller Bearing	4	0704031	0704436
5	Roller	2	0182404	0183005
6	Keeper Bar	1	2252401	2383001
7	Roller Cage Weldment	1	0112404	0113004
8	Bearing Spacer	2	0182414	0183015



www.barroneq.com

**Barron Equipment & Overhead Doors 8000
4710 N Brady St
Davenport, IA 52806**

(800) 397-6690 Toll Free